

WINSLOW TOWNSHIP HIGH SCHOOL

PROGRAM OF STUDIES 2021-22

DISTRICT MISSION STATEMENT

The Mission of the Winslow Township School District, a large, diverse and growing community, is to educate all students to become independent, life-long learners, critical thinkers, caring and confident members of their community. The District, in partnership with the community, and in a climate of cooperation and mutual respect, will provide an academic environment which values excellence and diversity, encourages students to strive for personal excellence, and assists them in acquiring the knowledge, skills and attitudes necessary to contribute positively to a rapidly changing world. (Board Approval Date: March 7, 2002)

DISTRICT AFFIRMATIVE ACTION STATEMENT

The Winslow Township School District does not discriminate on the basis of race, color, national origin, sex, disability, or age in its educational programs and activities, in accordance with the requirements of Title VI of the Civil Rights Act of 1964 (Title VI); Title IX of the Education Amendments of 1973 (Title IX); Section 504 of the Rehabilitation Act (Section 504); the Americans with Disabilities Act of 1990 (the ADA); or the Age Discrimination Act of 1975 (the Age Discrimination Act), which prohibit discrimination on the basis of race, color, national origin, sex, disability and age, respectively.

If you have questions regarding the district's responsibilities under these regulations, if you wish to make a complaint, or if you require services related to a disability pursuant to Section 504 and the ADA, please contact the following individual(s) designated to coordinate the district's efforts to comply with Title IX, which prohibits discrimination based on sex, Section 504 and the ADA, which prohibit discrimination based on disability, and the Age Discrimination Act, which prohibits discrimination based on age:

Affirmative Action Officer/504 Officer:
Mr. Dion Davis Winslow Township Board of Education
40 Cooper Folly Road
Atco, NJ 08004
856-767-2850

For further information, contact:

United States Department of Education, Office of Civil Rights – New York
Office, at 32 Old Slip, 26th Floor, New York, New York 10005-2500,
Phone: 646-428-3900; Fax: 646-428-3843
E-mail address: OCR New York@ed.gov.

WINSLOW TOWNSHIP SCHOOL DISTRICT
BOARD OF EDUCATION

Cheryl Pitts, President
Julie Peterson, Vice President
Larry Blake
Lorraine Dredden
Rita Martin
Abena McClendon
Cynthia Moore
John Shaw, Jr.
Kelly Thomas

DISTRICT ADMINISTRATION

Dr. H. Major Poteat, Superintendent
Dr. Dorothy Carcamo, Assistant Superintendent
Tyra McCoy, Business Administrator/Board Secretary
Dion Davis, Director of Human Resources
Robert Riccardi, Director of Pupil Services
Karen Loney, Director of Evaluation, Research and Planning
John Gaskill, Transportation Coordinator
Michele Nisula, Supervisor of Language Arts Literacy
John Innocenzo, Supervisor of Mathematics

HIGH SCHOOL ADMINISTRATION

Kurtis Marella, Principal
Chris Chambers, Assistant Principal
Richard Dawkins, Assistant Principal
William Shropshire, Assistant Principal
Lynette Brown, Assistant Principal
Mark Whittaker, Athletic Director

WINSLOW TOWNSHIP HIGH SCHOOL
Phone (856) 767-1850 Fax (856) 767-5670
10 Cooper Folly Road
Atco, New Jersey 08004-2620

MESSAGE FROM THE PRINCIPAL

The goal of Winslow Township High School is to prepare all students to excel in this rapidly, ever-changing world. We at Winslow Township High School are committed to this goal and work tirelessly to provide a superior educational experience. This goal is accomplished through the utilization of cutting-edge technology, expansive curriculum, specialized programs, cooperative learning and differentiated instruction.

Our entire staff is sensitive to the needs of students as individuals. We take pride in designing interesting, challenging and engaging experiences that allow our students time for self-discovery, while continuing their exploration of the world at large. High standards and expectations will guide students toward the expected outcome of academic success and the ability to thrive in the 21st century.

We will continue to focus efforts on providing a safe and empowering environment for learning. We will emphasize the importance of character development and constructive decision-making.

We believe in a strong and ongoing partnership with parents and guardians for our students' academic successes as well as social and emotional development. We believe achievement is directly related to parental involvement and in creating a cohesive support system.

Winslow Township High School continues to strive for excellence. The common goal of administration and staff is to provide students with superior educational opportunities that will enable our students to excel in college, post-secondary school, careers and ultimately, life.

Proud to be an Eagle,

Kurt Marella
Principal

INTRODUCTION

To the student and parent: This program of studies is a valuable reference for students, parents, and school personnel actively involved in curriculum planning at Winslow Township High School. This manual is intended to be a complete guide to the course offerings at Winslow Township High School. Each departmental area has described its specific course offerings, highlighting requirements and prerequisites.

PROGRAM AND SCHEDULE PLANNING

Planning an individual student's high school program of studies demands cooperation among the student, the home, and the school. The program of studies that a student pursues in high school should reflect his or her aspirations, achievements, aptitudes, and skills. Students should be encouraged to select courses that are academically challenging and personally stimulating and enriching. There is a four-year program planner, in the back of this guide, provided for your use in considering course selections.

In selecting courses, the following criteria should be considered.

Does the course:

- a. Meet the high school requirements for graduation?
- b. Meet college entrance requirements?
- c. Provide a background for post-high school plans?
- d. Provide opportunities to satisfy interests in specific subjects?

Please note the following when planning your program:

- Make sound initial choices of courses, as well as plan alternate course options. Initial low enrollment totals for courses may lead to a cancellation of a course, thus decreasing the options for change once the master schedule is complete.
- Choose courses not teachers. Students and parents should not make the mistake of choosing or refusing a course based on their perception of a particular instructor – each choice should be based on the merits of the course content and its value to the student's specific needs. Please understand that requests for schedule adjustments based on the issue of personnel will not be honored.
- Discuss specific subject area choices with teachers, department chairs, and school counselors who can share valuable insight into the nature of specific courses.
- When planning course level placement, consider taking the most challenging course load that you can handle.
- Students who are considering going to college should keep in mind that the minimum number of academic units required for college admission typically include:

College Prep English – 4 Years

College Prep Math (Algebra I, II, and Geometry) – 3 Years

Laboratory Sciences (Lab Biology, Chemistry, and an additional laboratory /inquiry-based science) – 3 Years

College Prep Social Studies (World History, U.S. History I, II) – 3 Years

Foreign Language – 2 Years

Academic Electives – 2 Years

Although colleges vary in their selectivity, it is strongly recommended that students take more than the bare minimum if they hope to be competitive. Colleges will expect to see a high level of academic preparation reflected in high school courses, grades, grade point average, and standardized test scores. Ideally, a college bound student should be prepared to take four (4) years each of college level English, Mathematics, Science, and Social Studies courses. In addition, because colleges are also interested in securing “well-rounded” students, participation in extra-curricular activities is also advisable.

Parents are encouraged to participate in the development, support, and monitoring of this four-year plan through regular communication with the Guidance and Counseling department. Conferences may be arranged by calling 856-767-1850, extension 8100.

The programs that individuals pursue in high school should reflect their aspirations, aptitudes, and achievements. Because individuals differ, programs too, must differ. Since post-high school requirements for employment, college, or vocational-technical training are constantly changing, students must frequently reevaluate themselves in terms of their immediate and long-range goals.

The courses at Winslow Township High School provide students the opportunity to meet their educational needs in accordance with their individuality and career paths. These courses are selected as part of a four-year plan that will prepare students for success in their post-secondary lives. Every effort is made to provide students with a program that is suited to their individual learning styles and needs. Should students experience academic difficulty in reading, writing, and/or mathematics, they may receive supplemental instruction upon the recommendation of the teacher, school counselor, or case manager. If learning difficulties are identified, consultation with the parent/guardian will be scheduled. The student may be referred to the building Intervention and Referral Services (I & RS) Committee, for a case review, or to the Child Study Team for evaluation.

ACADEMIC PROGRAMS REQUIREMENTS FOR GRADUATION

In order for a student to receive a high school diploma from Winslow Township High School, each student must complete the following:

A. Testing Requirements

Pass the New Jersey Student Learning Assessment (NJSLA) as outline by the New Jersey Department of Education. (Please see assessment requirement chart on the NJDOE website at www.state.nj.us/education/assessment/parents/GradReq.pdf)

Students in the class of 2021 can demonstrate graduation proficiency through three pathways:

1. Achieve a passing score on NJSLA/PARCC Algebra I, Geometry, Algebra II and English Language Arts/Literacy grade 9, 10, 11 assessment.

2. Achieve New Jersey Department of Education cut scores on designated alternative assessments (SAT, ACT, Accuplacer, ASVAB, PSAT 10.
3. The submission by the district of a student portfolio through the Department of Education’s portfolio appeals process.

B. Course Requirements

Students must successfully complete a minimum of 120 credits during their high school years. The course work requirements for graduation must include the following courses:

English Language Arts-	4 years-	20 credits
Mathematics (Algebra, Geometry, Algebra II)	3 years-.....	15 credits
Science (Biology, and 2 additional years of lab science)	3years-	15 credits
U.S. History (U.S. I and U.S. II)	2 years	10 credits
World History	1 year-	5 credits
Physical Education and Health & Safety-.....	1 course for each year	of public high school enrollment in New Jersey.
Visual, Practical and Performing Arts-	1 year-	5 credits
Career Education: Consumer, Family, and Life Skills-...1 year-	5 credits	
World Language-	1 year-	5 credits
Economics/Financial Literacy -	1 semester-	2.5 credits
Elective-		20 credits

COURSE LEVELS AND GROUPING

The Winslow Township Board of Education recognizes that it is advantageous to provide varying levels of difficulty in the same course in many academic areas. The intent of offering multiple levels or groups is to ensure that all students, including the most academically talented, can participate in courses where instruction is challenging. For purposes of computing grade point average and class rank, the ability levels are grouped into four (4) categories: Level IV (Advanced Placement); Level III (Honors); Level II (College Prep); Level I (Modified / Remedial / General / Introductory).

The following are the course level designations for the course offerings described in this booklet, each with a brief explanation:

Level IV - Advanced Placement: These courses follow the curriculum recommended by the College Entrance Examination Board. Students who enroll in these courses are expected to take the Advanced Placement test for that course offered by the Educational Testing Service (ETS). Students who elect to take the Advanced Placement Test will pay for each test they choose to take. If the student earns grades of 3 or above in any of these tests, he/she may be reimbursed, by the District, for the cost of those tests. Students who elect to take the Advanced Placement test may be awarded credit or advanced placement by the college they choose to attend. Requests for reimbursement must be submitted to the attention of the Assistant Superintendent by September 30th of the following school year.

Students will be required to submit payment for any advanced placement test fee. If a student receives a score of 3 or higher on the advanced placement test, it might be possible to:

1. Receive college credit
2. Be granted a course exemption in college
3. Gain tuition savings
4. Explore more advanced undergraduate subject areas
5. Gain eligibility for honors and other special programs in college

Level III - Honors: Honors courses are designed to challenge highly motivated, academically talented, and self-directed students. These courses often include a more in-depth study of a particular subject accompanied by rigorous demands upon students in terms of study skills, homework, and independent projects. Instructional strategies for honors courses closely resemble those utilized in colleges and universities. Students selecting honors level courses should be prepared for these added expectations.

Level II - College Prep: College preparatory courses in English, Social Studies, Mathematics, Science, and World Languages are designed to challenge academically motivated students. These courses fulfill the Academic Units required by the majority of four-year colleges and universities. Courses at this level require in-depth study of the particular subject. Success in these courses requires that a student display a high level of study skills, complete required homework and assignments, and be able to produce independent projects. The demanding pace of these courses will prepare students to meet the more rigorous requirements found at many colleges and universities.

Level I - General Education: These courses are designed to equip students with the skills necessary to meet the demands of the programs offered at most two-year colleges, technical schools and the world of work. In addition to mastering the particular subject, students are expected to successfully complete required homework, class-work, and projects. (Note: Level I-General Education courses do not meet the requirements of NCAA Clearing House and may not be accepted at many four-year colleges.)

Level I - Special Education: Students that are determined eligible for special education and related services may enroll in special courses in any area that impacts achievement in the general curriculum. The courses offered, for students eligible for special services, follow the general curriculum courses of study with modifications and adaptations made on an individual basis based on the student's IEP. In general, special education can take place in a variety of educational settings including the regular education classroom. The Winslow Township Board of Education offers special education options within the continuum of placements as described in N.J.A.C. 6A:14. This wide range of educational options maximizes the student's opportunity to experience success in the school setting. Students will not be excluded from participating in a curricular or co-curricular activity on the basis of their disability.
(Note: Some Level I -Special Ed/Modified Education courses meet the requirements of NCAA Clearing House.)

EDUCATIONAL PROGRAM OPTIONS

The Winslow Township Board of Education recognizes that students have different needs and aspirations. To respond to these different needs the Winslow Township High School has developed several educational program options that you may wish to consider as you plan for your educational program. All of the Educational Program Options will require completion of a contract/ agreement form that outlines the parameters of the individual program options. All programs that may be available are listed below.

Accelerated Program: Students who have demonstrated outstanding academic performance will be permitted to enroll in more than one course in a departmental area or enroll in a course sequence earlier than would be expected. Students who participate in an accelerated program must earn a grade of at least 83 in the departmental area in which the course sequence will be accelerated. Students who elect to accelerate, prior to high school, do not receive high school credit for courses taken prior to high school. Moreover, these courses do not satisfy requirements for graduation. Students who have completed Algebra Honors in Grade 8 may be accelerated in Grade 9 to Geometry Honors if they have earned a final grade of 83 or better in Algebra Honors, have passed the WTHS Algebra I Honors exam that will be administered to all grade 8 students in Algebra Honors, and have received their teacher's recommendation.

Advanced Placement Program: Winslow Township High School participates in the Advanced Placement Program sponsored by the College Board which provides students with the opportunity to earn college credit while still in high school. Advanced placement courses are very rigorous, and the expectations of the students are very high. Advanced placement courses are listed under the various departmental headings. Students enrolling in advanced placement courses are required to take the advanced placement examination in order to receive advanced placement weighting. Those students that do not take the examination will receive the weight of an honors level course.

Community Service Program: The Community Service Program enables students in grade 11-12 to select and become active participants in a community-based project. Students must arrange their elective service program as a result of their own independent search. Upon approval by the Administration, academic credit may be earned by participating in a community project. Students may elect to earn up to five credits during a school year depending on the number of hours dedicated to the project (1.25 credits = 30 hours of documented service each quarter). Students who participate in a community project to earn credit must identify a school district advisor who will assist the student in meeting the program requirements. A contact representative (not a relative) will also need to be identified from the organization where the community service project will occur. This representative must serve as a sponsor and assist the school advisor in planning, organizing, and monitoring the progress on the project. Forms for applying for a community service project are available in the high school counseling office. College bound students are encouraged to participate. Community service credit is available from September to the first Friday in June during the current school year.

Dual Enrollment College Credit Courses- The double-starred (**) statements in our course descriptions indicate that the course is eligible for college credit from Rowan College at Burlington County, Rowan College of South Jersey, Camden County College and/or Stockton University. All college course titles are listed after the college course eligibility statement in our course description. College course titles are subject to change after this publication. Please see your guidance counselor for assistance prior to registering for college courses. Students that are enrolled in Career and Technology Education (CTE) dual credit courses may receive tuition reimburse, if available, by earning a grade of a B or better. Students that qualify must submit proof of payment and grade to the Building Principal by June 30th of that school year.

Career and Technology Education and Dual Credit Courses: The following courses have been identified as CTE courses: 1) Introduction to Digital Design; 2) Digital Imaging 1; 3) Mass Media; 4) Television Production 1; 5) Early Childhood Development II; and 6) Early Childhood Development III

Early Graduation: To be considered for early graduation, students must, 1. Submit an early graduation request which is subject to review by the Building Principal with final approval granted by the Assistant Superintendent. 2. Request for early graduation must be made by September 30th of the sophomore year. 3. The student must work with the counselor to develop a post-high school plan and provide written parental approval. 4. Must be in good academic standing.

Bridge Year Pilot Program: Under the bridge year, certain students in the classes of 2021 and 2022 who have met all their state and local graduation requirements may defer graduation from high school for one year to participate in an additional year of academic courses and extracurricular activities immediately following their senior year. Students that wish to participate in this program must notify the Building Principal by February 15th of their senior year. Please see Bridge Year Pilot Program (P.L. 2020, c. 41) Implementation Guidance on the State of New Jersey Department of Education website for full details or contact your guidance counselor for assistance.

Early Release: A senior may elect to enroll in Early Release if the student will have satisfied all graduation requirements by the period in the day that the student leaves the building. To satisfy State requirements, a pupil must attend school for a minimum of four (4) hours of instruction daily. Hence, Early Release can only be for periods 6-8. Parents must submit approval for Early Release. Participating seniors must have their own transportation from Winslow Township High School.

High School Credit for College Courses: Winslow Township High School will provide high school credit for courses taken at an approved college or university. This program option is limited primarily to courses not offered in the Winslow Township Program of Studies, unless a student's educational plan requires a modification of the school day. Application for this program option must be secured and must include signature from parent/guardian, school counselor, and principal. These courses will satisfy the requirements for graduation but will not be included in the grade point average or class rank. Forms for this option are available in the counseling office. All expenses

associated with enrollment in an educational institution other than WTHS are the responsibility of the student.

Independent Study Program: This program offers students the opportunity to pursue a course of study independently for credit. Independent study is not available as a program option in courses that are required for graduation. The Independent Study Program is available to those students in grades 11 and 12 who are looking for an additional academic opportunity for in-depth study beyond the present course offerings, or for those who desire to fulfill a course need that is not available in the current program of studies. Students will not be able to participate in an Independent Study Program if the course is offered in the program of studies and available to the students, or if they have not met the prerequisites. Although a course taken as an Independent Study promotes enrichment and allows for earning additional credits, the course will only receive a grade of Satisfactory (S) or Unsatisfactory (U) and will not be calculated as part of the GPA. Therefore, an independent study course has no bearing on a student's class rank or GPA.

The following steps must be taken in order for an independent study request to be granted:

- Certified teacher who is a member of the high school staff must agree to serve as the evaluator.
- The student and the cooperating teacher must collaborate in establishing the work and time requirements, the methods of evaluation, and the grading and credits to be earned. (1.25 credits for each marking period).
- A completed Independent Study Contract (available in the counseling office) must be submitted to the student's counselor and signed by the collaborating teacher.
- The student is responsible for getting the contract approved, signed by the parent/guardian, teacher and school counselor.
- A student may be withdrawn from independent study, if it is determined that he/she is not abiding by the contract terms. A student withdrawing from an independent study program must secure a schedule change from the school counselor.

Junior Reserve Officers Training Corp. (JROTC) and Leadership Training: Winslow Township High School provides course credit for students who participate in the United States Army JROTC Leadership Program.

Volunteer Service Program: The Volunteer Service Program offers 11th –12th grade students' credit for approved volunteer work in the school. Enrollment in this program is contingent upon approval of an application. Up to five credits per year may be earned by the student for successful completion of 30 hours of volunteer service per quarter (200 minutes per week). A student must be carrying a minimum of 30 credits to apply for volunteer service. Additionally, students must have passed a minimum of 30 credits, excluding volunteer service for the previous year. Volunteer service and its appropriate credit become part of the student's permanent record. This program is deemed valuable to help students develop self-discipline, pride in service to school, and career insights. Students must arrange for their elective volunteer service program through their own independent search. Upon approval, academic credit may be earned from 1.25 to 5.0 credits during the school year depending on the number of hours volunteered (1.25

credits = 30 hours of volunteer service). **Credits earned in the volunteer program are unweighted and will NOT calculate into a student's cumulative grade point average.** Students who volunteer must obtain a school district advisor to monitor their time and service. Students must maintain a detailed log of hours, signed weekly, by the school advisor. Volunteer program applications are available in the high school counseling office.

WINSLOW S.T.E.A.M. ACADEMY

The S.T.E.A.M. (Science, Technology, Engineering, Art, and Mathematics) Academy at Winslow Township High School is a rigorous four-year interdisciplinary program designed to provide a strong educational foundation for academically-gifted students planning on pursuing careers in science, technology, engineering, or mathematics. Students enrolled in this program should be prepared for challenging coursework and a variety of educational experiences.

Students who wish to receive a career certificate at the end of their senior year must complete the outlined course offerings in one of the seven S.T.E.A.M. Academy programs:

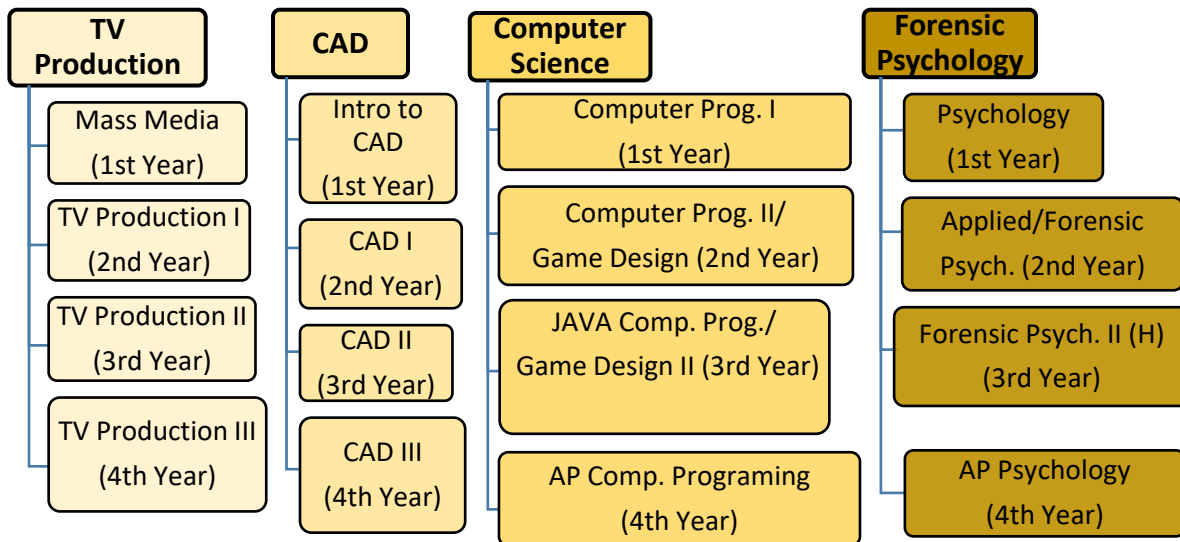

Students are also required to complete the following areas of mathematics and science

- 3 years of Science + 1 AP = 4 Years
- 3 years of Math + 1 AP = 4 Years

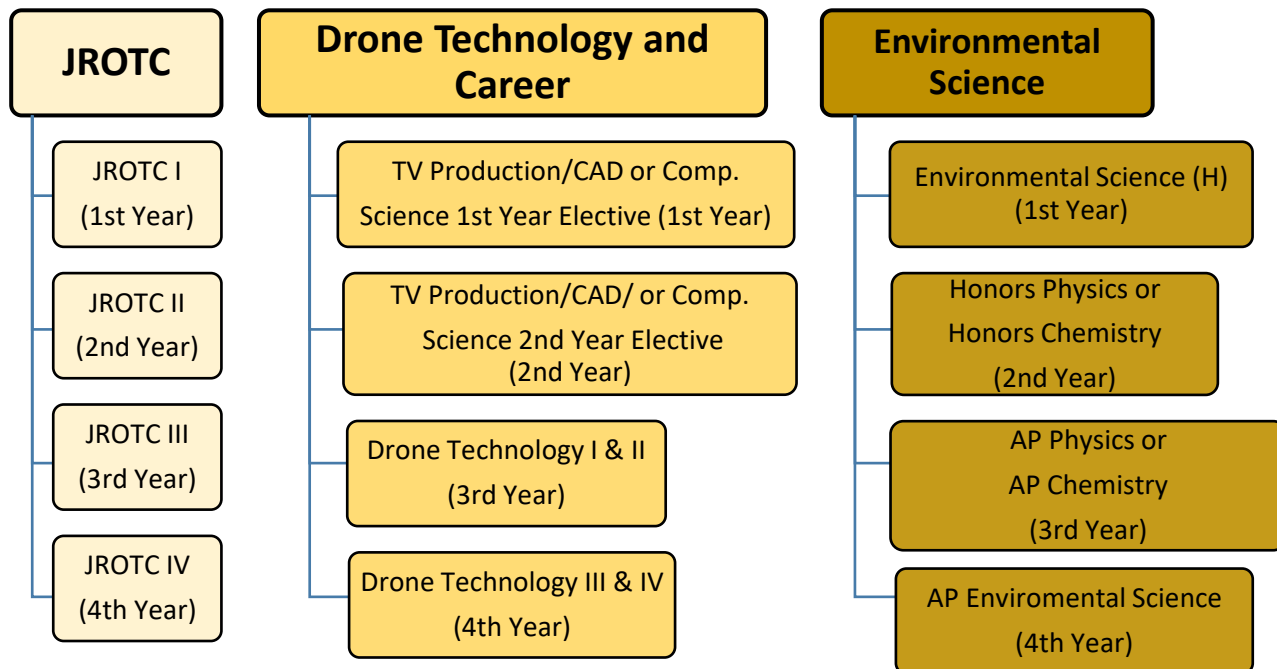

Students are also required to complete the following areas of mathematics and science

- 3 years of Science + 1 AP = 4 Years
- 3 years of Math + 1 AP = 4 Years

SELECTION CRITERIA FOR HONORS AND ADVANCED PLACEMENT COURSES

Students are encouraged to engage in the most challenging educational program possible. Selection criteria for honors and advanced placement courses are intended to provide students with guidance in terms of academic expectations and predict academic success.

Honors (H): Students enrolling in an honors course must earn a grade of 87 or better in a previous college prep course, in the appropriate course sequence, or secure a recommendation from a teacher in the same subject area. Students currently enrolled in honors courses must earn an 83 or better to continue at the honors level in that subject area.

Advanced Placement (AP): Students enrolling in an advanced placement course must earn a grade of 87 or better in a previous honors course, in the appropriate course sequence, or secure a teacher recommendation in the same subject area. Students may not enroll in an Advanced Placement Course after the first ten (10) school days. Students wishing to enroll in an advanced placement course coming from a college prep level course must have achieved a minimum grade average of 92 in that subject. Entry into an AP course in the English department requires enrollment in a prerequisite honors level course. Students enrolled in an AP course are expected to take the AP examination corresponding to the course in which they are enrolled in order to receive advanced

placement weighting. Students that do not take the examination will receive the weight of an honors level course. Students are responsible for the cost of the AP examinations. However, students who earn a score of 3 or higher may be reimbursed for each exam on which they earn that score.

ARMY JUNIOR RESERVE OFFICERS TRAINING CORPS (AJROTC)

Our Mission is: “TO MOTIVATE YOUNG PEOPLE TO BECOME BETTER CITIZENS.”

JROTC is a leadership and Character Development Program. The Program of Instruction is taught using the latest instructional technologies and focuses on student-centered learning in a structured environment. Through participation in the learning process, cadets are able to get a deeper understanding of the subjects and how they may apply to what they have learned.

Course #: 5330

Level: I

Grade/s: 9-10-11-12

Credits: 5

Course Title: **LEADERSHIP EDUCATION AND TRAINING I /JROTC**

Description: This first-year course is an introduction to cadet CITIZENSHIP and LEADERSHIP development through FOLLOWERSHIP. The program emphasizes Civics Values, Ethics, and Disciplinary Standards. Subjects include: Social Awareness, Self-Awareness, Self-Management, Relationship Skills, Responsible Decision Making, Leadership Labs of Drill Ceremonies, Physical Training and Cadet Challenge, Citizenship, and History of the Nation and JROTC, Map Reading, Communication, First Aid, Unlocking Your Potential, Power Learning, and selected optional subjects. Students are expected to earn a minimum grade of 72 in order to continue in the program.

Course #: 5335

Level: II

Grade/s: 10-11-12

Credits: 5

Course Title: **LEADERSHIP EDUCATION AND TRAINING II/JROTC**

Description: The second-year course focuses on the intermediate level of cadet CITIZENSHIP and LEADERSHIP development. The program emphasizes training the junior noncommissioned officer cadet in the techniques of being capable and confident small unit leaders through the transition of FOLLOWERSHIP to LEADERSHIP. New subjects include: Mapping and Compass, First Aid/ROTC Opportunities, Military History, Basic Skills Review, and selected optional subjects.

Prerequisite: A minimum grade of 72 in JROTC I and be recommended by JROTC Instructors.

Course #: 5340

Level: II

Grade/s: 11-12

Credits: 5

Course Title: **LEADERSHIP EDUCATION AND TRAINING III/JROTC**

Description: The third year focuses on applied cadet CITIZENSHIP and LEADERSHIP development. The program emphasizes Power Learning, Civics Values, Ethics and Disciplinary Standards, Management of Resource and time Considerations.

New subjects include: Research, Command, Staff Functions and Procedures, Organization and Management, Time Constraints and Utilization, Training and Evaluations, Cultural Diversity, Current Events, and selected optional subjects.

Prerequisite: A minimum grade of 72 in JROTC II and be recommended by JROTC Instructors.

Course #: 5345

Level: II

Grade: 12

Credits: 5

Course Title: **LEADERSHIP EDUCATION AND TRAINING IV/JROTC**

Description: The fourth year course is advanced cadet CITIZENSHIP and LEADERSHIP development. The program emphasizes Leadership, Values and Ethics.

New subjects include: Psychology of Leadership, Seminar in Leadership and Management, Large and Small Unit Leadership Problems, Command and Staff, Military Technical Skills, selected optional subjects.

Prerequisite: A minimum grade of 72 in JROTC III and be recommended by JROTC Instructors.

**ART AND MEDIA
SUGGESTED COURSE SEQUENCES**

All courses meet visual performing arts requirements for graduation.

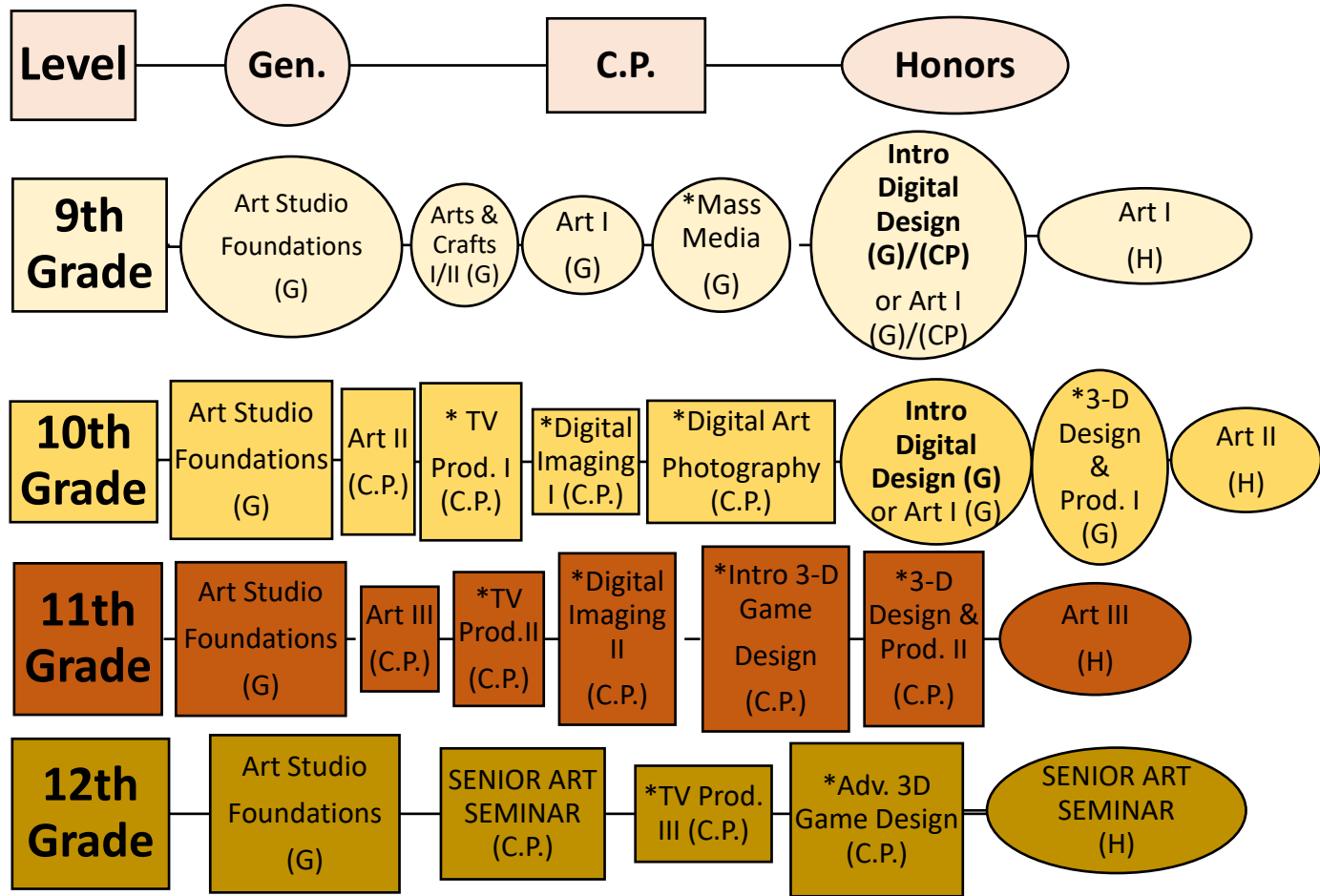

*Indicates courses that meet graduation requirements for 21st Century Life & Careers or careers technical.

Course #: 4640

Level: I

Grade/s: 9-10-11-12

Credits: 2.5

Course Title: **ART STUDIO FOUNDATIONS (SEMESTER COURSE)**

Description: This semester course will introduce students to the basic elements of art. It will provide an overview of various art techniques demonstrated through rigorous

projects on a smaller scale. Content will provide a foundation for further study in the areas of Art I. Art Studio Foundations is designed to provide a foundation for advanced courses. Emphasis is placed on understanding the Elements of Art and Principles of Design as a basis for composition. Students will explore a variety of artists, art processes and materials such as drawing, painting, printmaking, and two & three-dimensional design. Student artwork will reflect aesthetics and cultural and historical contexts. Willingness to get involved in the creative process is the main focus rather than the student's talent level or previous experience.

Course #: 4635 / 4636

Level: I

Grade/s: 9-10-11-12

Credits: 5

Course Title: **ART I/HONORS ART I**

Description: Art I is a course designed to teach the basics of art using the elements and principals of design. A variety of projects will be covered which may include drawing, color theory, lettering, perspective drawing and painting. Some of the media which may be used are pencil, colored pencil, markers, charcoal, pastels, watercolors and tempera paint. Art history will be introduced at this level. Students will also participate in individual and group critiques. Homework will be given which may be in the form of preliminary drawings, color theory assignments and research for projects.

Art I Honors for incoming ninth graders by middle school teacher recommendation only.

Art I Honors for 10-11-12 by portfolio submission and critique by the art teachers.

Course #: 4637

Level: I

Grade/s: 9-10-11-12

Credits: 2.5 – SEMESTER COURSE

Course Title: **ARTS & CRAFTS I**

Description: Arts & Crafts 1 is a course designed for the student who likes to work with his/her hands and explore a wide variety of arts and craft materials. The course covers a diverse array of projects in a non-sequential format which include drawing, weaving, cultural projects, fabric designs, metal repousse, decoupage and other craft activities. Students will also participate in individual and group critiques.

Course #: 4638

Level: I

Grade/s: 9-10-11-12

Credits: 2.5 – SEMESTER COURSE

Course Title: **ARTS & CRAFTS II**

Description: Arts & Crafts II is a continuation of Arts & Crafts I where students expand their knowledge of creative arts and craft materials. This course increases the level of complexity of projects and requires students to be active participants through individual and group critiques as they continue their study of drawing, weaving, fabric designs, metaled posse, decoupage, and other craft activities.

Course #: 4645 / 4646

Level: II / III

Grade/s: 10-11-12

Credits: 5

Course Title: **ART II / HONORS ART II**

Description: Art II is the second level of Art I. All media and techniques explored in first level art classes will be reviewed and explored once again, on a more in-depth level, to further develop art concepts, skills and individual styles and techniques. Students will be given the opportunity to evaluate various artists, techniques, and styles through the study of art history.

Prerequisites: Art I or Art I Honors

Course #: 4649

Level: II

Grade/s: 10-11-12

Credits: 5

Course Title: **3D DESIGN AND PRODUCTION**

Description: Three-Dimensional (3D) Design and Production is a unique multi-media course with a dual focus on the creative elements of design and practical aspects of entrepreneurship. Students will be taught the elements of 3D Design and then will be guided in the creation of commercial-quality 3D products. Instruction and experience in the basic aspects of entrepreneurship will be provided through a business cycle that will provide self-sustaining production and sales of student-generated art products.

Prerequisite: Art I and recommendation of teacher. Academic course study or work experience is strongly encouraged.

Course #: 4650 / 4651

Level: II / III

Grade/s: 11-12

Credits: 5

Course Title: **ART III / HONORS ART III**

Description: Art III is designed to give the serious art student an opportunity to apply skills in drawing, painting, printmaking, sculpture, crafts and art history. Methods and advanced techniques in color theory, pastels, watercolors, acrylics, printing, sculpture and ceramics will be presented. An emphasis will be placed on individual projects at this level. Course requirements include projects, art history reports, tests and possibly a homework assignment in the form of a sketchbook.

Prerequisite: Art II or Art II Honors

Course #: 4655 / 4656

Level: II / III

Grade: 12

Credits: 5

Course Title: **SENIOR ART SEMINAR (S.A.S.) HONORS SENIOR ART SEMINAR**

Description: S.A.S. is designed for the artistically talented, career directed student who has completed the basic art courses. Emphasis is placed on individual in-depth study on

an advanced level, with direction and appropriate training necessary to realize job criteria and the preparation of a portfolio. Practical application of all previous skills and previously taught techniques will be utilized towards art service for various clubs, school functions, etc. At the end of the school year, the S.A.S. student will be expected to present a portfolio and a Senior Art Exhibit.

Prerequisite: Art III or Art III Honors

Course #: 4660

Level: II

Grade/s: 10-11-12

Credits: 5

Course Title: **DIGITAL ART PHOTOGRAPHY**

Description: Digital Art Photography will acquaint the student with the basics of both color and black and white photography. Adobe Photoshop will be utilized for image editing. The study of lenses, light meters, filters, flash, tripods and mounting will be explored extensively. Additional topics covered are continuous tone photography, photojournalism, paparazzi, school activities, night photography, experimental camera work, darkroom techniques and the history of photography. The school provides digital cameras, but students are encouraged to use their own equipment.

Prerequisite: Art I or Intro. To Digital Design

Course #: 4675

Level: I

Grade/s: 9-10-11-12

Credits: 5

**Eligible for college credits from Rowan College of South Jersey- listed as Design, Color & Type

Course Title: **INTRODUCTION TO DIGITAL DESIGN**

Description: This introductory course allows students to explore the modern realm of computer graphics art and design. Students are provided with the unique opportunity of experiencing the latest industry trends. In this combined studio/lecture course, students will create and share a variety of products such as mechanical layouts and visual applications aligned with today's digital world. Emphasis is placed on the visual-problem solving process using applications and equipment, including but not limited to the Adobe software suite. Students will be able to utilize a variety of software and hardware which includes both web and print based graphics. This hands-on experience will allow them to complete the course with an electronically produced a comprehensive portfolio presentation.

Course #: 4681

Level: II

Grade/s: 10-11-12

Credits: 5

**Eligible for college credits from Rowan College of South Jersey- listed as Electronic Illustration 1

Course Title: **DIGITAL IMAGING I**

Description: This course will provide studio experience in computer graphics art and design. This combined studio/lecture course is an introduction to the creative possibilities of graphics computing. Emphasis is placed on the visual-problem solving process through the use of applications and equipment. Students will be able to utilize a variety of software and hardware which includes bit-mapped point and object-oriented programs such as Adobe Photoshop and Adobe Illustrator.

Prerequisite: Introduction to Digital Design

Course #: 4683

Level: II

Grade/s: 11-12

Credits: 5

Course Title: **DIGITAL IMAGING II**

Description: This course will provide advanced studio experience in Computer Graphics Art and Design. This combined studio and lecture course is a continuation of the material/programs learned in Digital Imaging I. The students will work at an advanced level using both Adobe Photoshop and Illustrator CS2 along with other imaging editing software. Emphasis is placed on the visual problem-solving process using “real world” applications and equipment. Other topics explored include rollovers, animations, and web-ready graphics.

Prerequisite: Digital Imaging I

Course #: 4690

Level: I

Grade: 9-10-11-12

Credits: 2.5

**Eligible for college credits from Rowan College of South Jersey- listed as Mass Media

Course Title: **MASS MEDIA**

Description: This course will provide students with the opportunity to learn the basics of television studio production. This course emphasizes both methods and hands-on experience in video production. Mass Media covers the history of production equipment, communications models, pre-production planning, camera use and sound recording techniques. This course will provide students with the opportunity to learn the basics of the technical side of TV production such as using video tape recorders and producing news segments. Students will also learn the MAC OS operating system, which is industry standard in the TV Production field.

Course #: 4697

Level: II

Grade/s: 10-11-12

Credits: 5

**Eligible for college credits from Rowan College of South Jersey- listed as Applied Media Aesthetics

**Eligible for college credits from Stockton University listed as Television Production

Course Title: **TELEVISION PRODUCTION / RADIO BROADCASTING I (CP)**

Description: This course will allow students to refine and expand the skills acquired in Mass Media and receive advanced instruction in electronic news gathering and other

programming formats. Students will learn advanced techniques in lighting and audio. Students will learn non-linear editing using the Apple iMovie Software. Emphasis will be placed on completing independent study assignment in which students will demonstrate the ability to organize, write and work cooperatively and professionally. Honors Television Production II will progress at an accelerated pace and will examine equipment and skills in a more in-depth level. Students will complete projects such as PSA's, Music Videos, and News Broadcast.

Prerequisite: A grade of 87 or better in Mass Media and/or teacher recommendation.

Course #: 4702

Level: III

Grade/s: 11-12

Credits: 5

Course Title: **TELEVISION PRODUCTION/RADIO BROADCASTING II Honors**

Description: This course will allow students to use production skills acquired in Television Production II to produce news segments and receive advanced instruction in documentary, news magazine, hybrid drama and other popular programming formats. Students will learn advanced techniques in location lighting and set design. Students will learn and build non-linear editing skills by using the Apple Final Cut Pro Studio Editing Software. Emphasis will be placed on completing independent study assignments in which students will demonstrate the ability to organize, write and work cooperatively and professionally. Students will work to complete a short docudrama, narrative and green screen technology. Students will learn advanced techniques in pre-production planning including extensive treatments, production budgets, hiring talent and scouting locations. Emphasis will be placed on completing prolonged television productions in which students will demonstrate the ability to organize, write and produce professional television programs. Students will work to complete a panel program, a documentary, a narrative and several full-length productions

Prerequisite: 87 or better in Television Production I

Course #: 4703

Level: III

Grade: 12

Credits: 5

Course Title: **TELEVISION PRODUCTION / RADIO BROADCASTING III (H)**

Description: This course will allow students to use production skills acquired in Television Production III to advance in Professional Post-Production Skills. Students will go extremely in depth with the Apple Final Cut Pro Studio Editing System. The goal for the course is for students to excel in professional techniques such as; Sound Design, Sound Engineering for TV and Video, Color Correction, Motion Graphics, Compression, and Podcasting. Students will work toward receiving Apple Certification which will increase their chances of getting work in the field and being accepted to college. Students will record and complete a full-length project which will display all skills developed from Television Production I through Television Production IV. Emphasis will be placed on completing prolonged television production in which students will demonstrate the ability to use the Apple Final Cut Pro Studio Edition System.

Prerequisite: 87 or better in Television Production II

Course #: 464800
 Level: II
 Grade/s: 11-12
 Credits: 5

Course Title: **3D Design**

Description: This course will help students transition from and understand the relationship between two and three dimensional images. With the advancement of today's digital media, such as online retailers, phone apps, television, film, etc., being able to draw in both 2 and 3D is a necessary skill. Students will demonstrate an understanding of multi view drawings, isometrics and perspective while still incorporating the Elements of Art and Principles of Design. They will explore drawing in proportion both manually and digitally as well as both statically and through the exploration of simple animation. Students will have the opportunity to use a multitude of software programs throughout the year.

Prerequisite: Introduction to Digital Design with a minimum grade of 85 or teacher approval.

**BUSINESS EDUCATION
 SUGGESTED COURSE SEQUENCES**

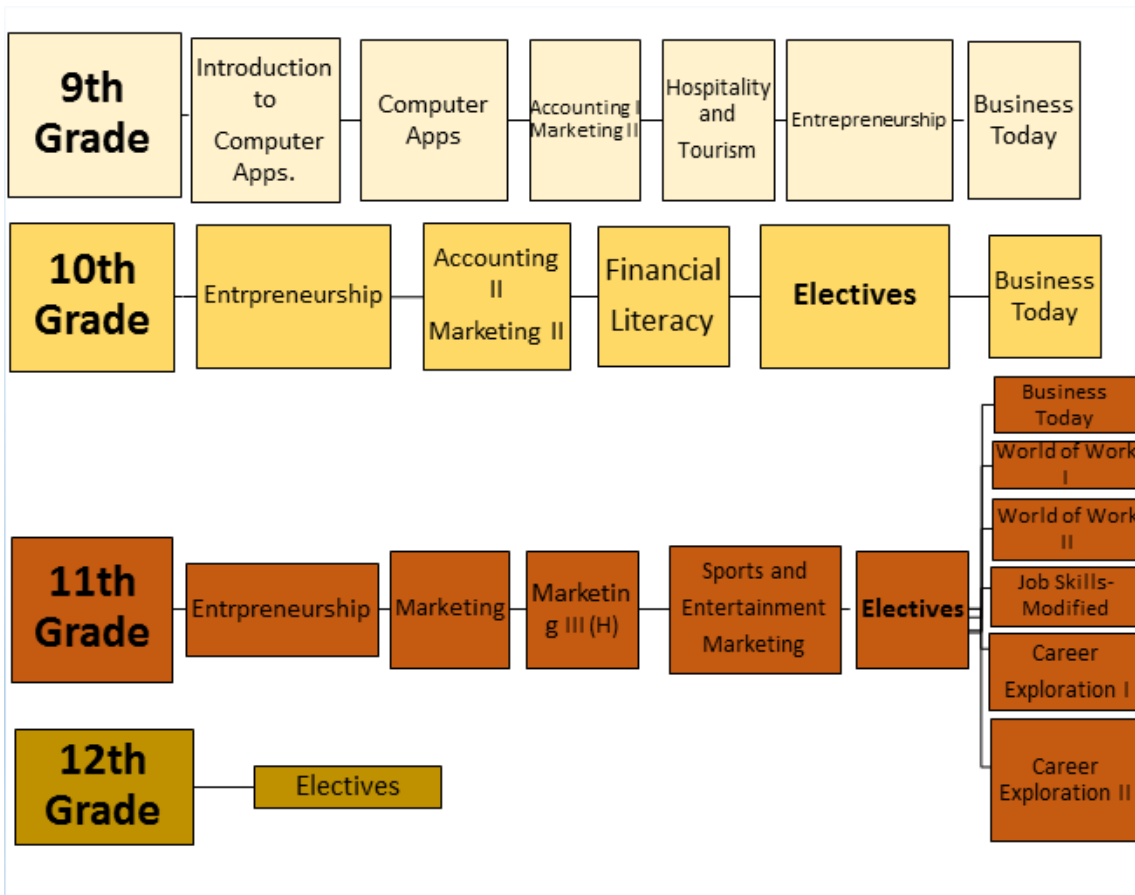

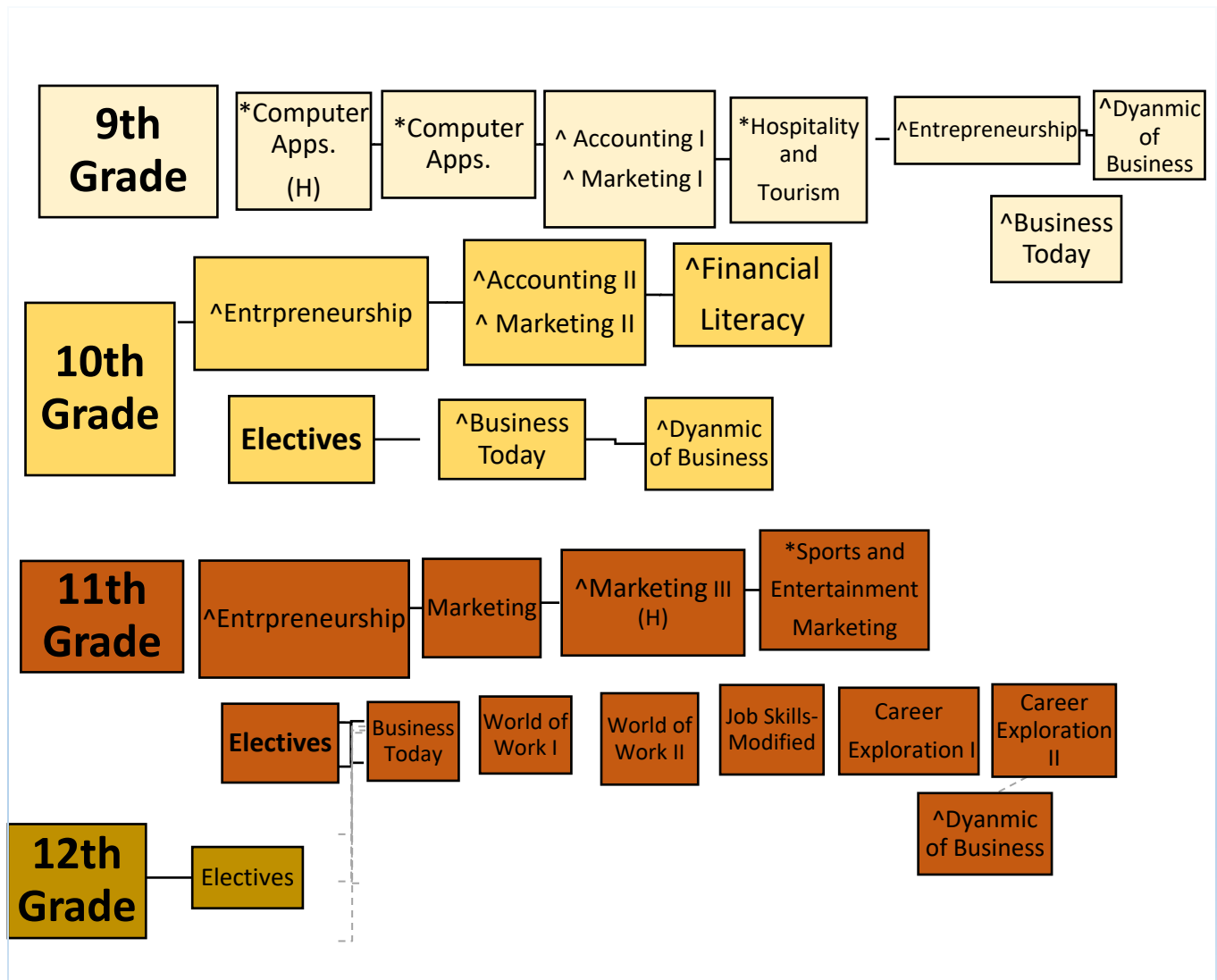

^- Courses fulfill the personal financial literacy requirement for graduation.

All Business courses meet graduation requirements for 21st Century Life and Careers or Career-Technical Education. Courses with (*) also meet Visual/Performing Arts requirements.

Introduction: Courses offered by the business education department serve many purposes: (1) they are designed to prepare students for entry-level careers in business, (2) they have useful and practical applications for the college-bound student, and (3) they serve to give all students practical and useful life skills information.

Course #: 4471

Level: II

Grade/s: 9-10-11-12

Credits: 2.5

Course Title: **ACCOUNTING I**

Description: Accounting I is a course designed to acquaint students with the basic terms and principles of accounting. These principles are then applied to problems similar to those that might arise in a business. Computerized accounting is a major component in this course and may be used to reinforce accounting principles. Mastering these basic principles and concepts will better prepare the student for careers in finance, marketing, business and accounting.

Course #: 4475

Level: II

Grade/s: 10-11-12

Credits: 5

Course Title: **ACCOUNTING II**

Description: Accounting II is the second in the sequence of basic accounting courses and is designed to provide an extension of all the materials and principles learned in Accounting I. Based on the elements learned in Accounting I, the student will continue to apply his/her knowledge to more involved accounting principles and procedures. Students will further enhance their knowledge and skills with the use of computerized accounting methods.

Prerequisite: Accounting I

Course #: 4493

Level: II

Grade/s: 9-10-11-12

Credits: 2.5

Course Title: **MARKETING I**

Description: Marketing I, which is also known as Principles of Marketing is the first in a sequence of three classes designed as a program within the scope and guidelines of New Jersey Career and Technical Education. The course and program are consistent with a vision to prepare students to succeed as global citizens and for career opportunities of the 21st century and to support healthy economic growth within the State. This class is focused on providing students with a foundation in basic marketing principles which will serve as a foundation for more advanced learning as the program builds towards culmination. It includes instruction in buyer behavior and dynamics, principles of marketing research, demand analysis, cost-volume and profit relationships. The course curriculum instills Understanding by Design principles as well as Problem Based Learning assignments in each unit providing rigorous and relevant laboratory experiences designed to foment transferrable skills to real life situations. At completion of the course, sequence students will have demonstrated mastery of an introductory University Course in marketing. This course will be the prerequisite to Marketing II with a required grade of C or better.

Course #: 4494
Level: II
Grade/s: 10-11-12
Credits: 5

Course Title: **MARKETING II**

Description: Marketing II, also known as Marketing Applications is the second in a sequence of three classes designed as a Program within the scope and guidelines of the New Jersey Career and Technical Education. The course and program are consistent with a vision to prepare students to succeed as global citizens and for career opportunities of the 21st century and to support healthy economic growth within the State. This class incorporates the latest in marketing practices and technologies and is focused on offering students opportunities to apply their new knowledge as well as integrate fundamental concepts. Included is instruction in pricing theory, marketing campaign and strategic planning, market segments, advertising methods, sales operations and management, consumer relations, retailing and applications to specific products and markets. In particular, the course instills Understanding by Design principles and assigns a Problem Based Learning assignment in each unit providing rigorous and relevant laboratory experiences designed to foment transferrable skills to real life situations. Students will work with the school's Athletic Department, Drama Department, and Student Government to develop advertising, and manage sales for school events such as ticket sales and school merchandise. At the culmination of the course, sequence students will have demonstrated mastery of an introductory University Course in marketing.

Prerequisite: A grade of C or better in Marketing I or Sports and Entertainment Marketing

Course #: 4522
Level: II
Grade/s: 9-10-11-12
Credits: 2.5 – Semester Course

Course Title: **HOSPITALITY & TOURISM**

Description: This course will introduce students to the hospitality industry, its various components and available career opportunities. It will provide an overview of the structure and scope of the travel/tourism and hospitality industries. This course will examine the components of the tourism industry: transportation, accommodation, food and beverage, and attractions. Content will provide a foundation for further study in the areas of culinary arts, lodging, travel and tourism.

Course #: 4521
Level: II
Grade/s: 9-10-11-12
Credits: 2.5 – Semester Course

Course Title: **SPORTS & ENTERTAINMENT MARKETING**

Description: This course is designed to prepare students for marketing occupations in the area of sports and entertainment. They will take a look at the exciting and dynamic field of sports and entertainment marketing. One of the largest industries in the world, sports marketing provides a unique way of looking at the business world. This course will focus on the two main aspects of sports and entertainment marketing: 1) The

marketing of sports and entertainment, and 2) The marketing of non-sports products and services through sports. Students will discover why companies pay to be associated with a team or entertainer; how to ticket plans to fill the seats in the arena; why targeting your marketing efforts is so important and more.

Course #: 4495
Level: II
Grade/s: 11–12
Credits: 5

Course Title: **MARKETING III**

Description: Marketing III, also known as Exploring Marketing Careers, is the third class in a sequence of three classes designed as a Program within the scope and guidelines of the New Jersey Career and Technical Education. The primary focus of this course is to explore major career tracks with requisite skill identification and development. Students will research and explore real world connections through various careers while completing a project-based learning activity such as job shadowing within one of the career tracks. At the culmination of the course, sequence students will have demonstrated mastery of an introductory University Course in marketing. The course will assume the new Jersey State Department of Education Marketing model once finalized.

Prerequisite: A grade of C or better in Marketing II.

Course #: 4420 / 4421
Level: II / III
Grade/s: 9-10-11-12
Credits: 5

Course Title: **COMPUTER APPLICATIONS – HONORS COMPUTER APPLICATIONS**

Description: This course is designed for any student who is interested in learning to use software packages such as word processing, spreadsheets, graphics, communications, and data bases, presentation, publishing and integrated/combined programs, etc. Students will be required to produce original work throughout the year using various software. Students should have good math and communications skills. Students may take Computer Applications as an honors level course.

Prerequisite: Algebra I or Integrated Algebra I (may be taken concurrently): students electing Honors Computer Applications must first meet the honors prerequisite

Course #: 4505
Level: I
Grade/s: 9-10-11-12
Credits: 5

Course Title: **BUSINESS TODAY**

Description: This course is an introduction to and exploration of the "business world." Students enrolled in the course are actively involved with many experiences that convey the excitement of learning about business and business-related topics. They engage in simulation activities, meet and hear from business leaders and research specific relevant areas of business. Through this active involvement, the students gain an understanding of

the structure of American business, consumer economics, banking and bank statements, credit, taxes, money management, the roles of management and labor and the many career opportunities in the business community.

Course #: 4514

Level: I

Grade/s: 9-10-11-12

Credits: 2.5

Course Title: **ENTREPRENEURSHIP**

Description: This course is designed for students who want to upgrade their ability to succeed as an employee as well as an entrepreneur. Entrepreneurship will provide a rich problem-solving environment based on projects and interdisciplinary approaches. Students will learn basic concepts of business ownership and management needed to be successful entrepreneurs and also develop skills, knowledge, constructive attitudes and experiences that will enable them to function as creative self-confident individuals.

Course #: 4496

Level: I

Grade/s: 10-11-12

Credits: 5

Course Title: **DYNAMICS OF BUSINESS – Modified**

Description: This course is designed to give students skills relating to job-hunting, career preparation, financial management, budgeting, aspects of banking, consumer protection, understanding of federal and state tax preparation, decision-making, problem solving, and social responsibilities as a member of today's global society. The curriculum will be appropriately modified by varying teaching techniques, strategies and materials to meet the educational needs of special education students as reflected in their individual education program. This a modified version to the Business Today course.

Course #: 4518

Level: II

Grade/s: 9-10-11-12

Credits: 2.5

Course Title: **FINANCIAL LITERACY**

Description: This course is designed to give students the skills and practical knowledge necessary for understanding and managing their personal finances. The course begins with the necessary component of career choice to gaining and maintaining employment. The employment component progresses from the letter of application, resume preparation, job sources, job references and contacts. The student will participate in a mock interview. Maintaining a checking account, preparing a budget, applying for credit cards and loans, purchasing a car, renting an apartment, purchasing insurance, selecting other financial services, and the preparation of federal and state tax forms will be emphasized. Students will examine financial business statements and various business publications. The course will also give students an understanding of their personal rights and obligations under the law dealing with contracts, torts, insurance, property, marriage and employment. Current issues relating to business, consumerism and sexual harassment will be discussed.

Course #: 4459
Level: I
Grade/s: 9-10-11-12
Credits: 5

Course Title: **WORLD OF WORK - MODIFIED**

Description: This course focuses on the development of social skills, motivation, promptness, career planning, self-management and safety principles. Students will gain an understanding of the application process, interview process, wages, taxes, insurance and benefits. The course is intended to introduce the student to the world of work through classroom instruction before (or upon) entering employment. Emphasis will be placed on interpersonal skills, career planning, use of technology information and other tools. The students will use critical thinking, decision making and problem-solving skills. The curriculum will be appropriately modified by varying teaching techniques, strategies and materials to meet the educational needs of special education students as reflected in their Individual Education Program.

Course #: 4465
Level: I
Grade/s: 10-11-12
Credits: 5

Course Title: **WORLD OF WORK II - MODIFIED**

Description: This course will provide instruction in the key skills needed for obtaining and keeping a job. Topics that will be emphasized include: job seeking, completing a job application, resume writing, interviewing skills and skills that will enable students to maintain a job. Class size is limited and by selection only. The curriculum will be appropriately modified by varying teaching techniques, strategies and materials to meet the educational needs of special education students as reflected in their Individual Education Program.

Prerequisite: World of Work I

Course #: 4462 / 4530
Level: I & II (Modified)
Grade/s: 10-11-12
Credits: 5

Course Title: **CAREER EXPLORATION I & II**

Description: Students will explore career clusters and research the labor market for various careers using the transitional kits. These courses are designed to explore employment opportunities and careers such as: animal care, health services, electricity, landscaping, carpentry, retail stores, restaurants, and mechanical/fixing experiences. This course will provide career-based instruction (CBI) allowing students the opportunity to visit various career sites. Class size is limited and by selection only. The curriculum will be appropriately modified by varying teaching techniques, strategies and materials to meet the educational needs of special education students as reflected in their Individual Education Program.

**COMPUTER SCIENCE
SUGGESTED COURSE SEQUENCES**

These courses meet graduation requirements for 21st Century Careers

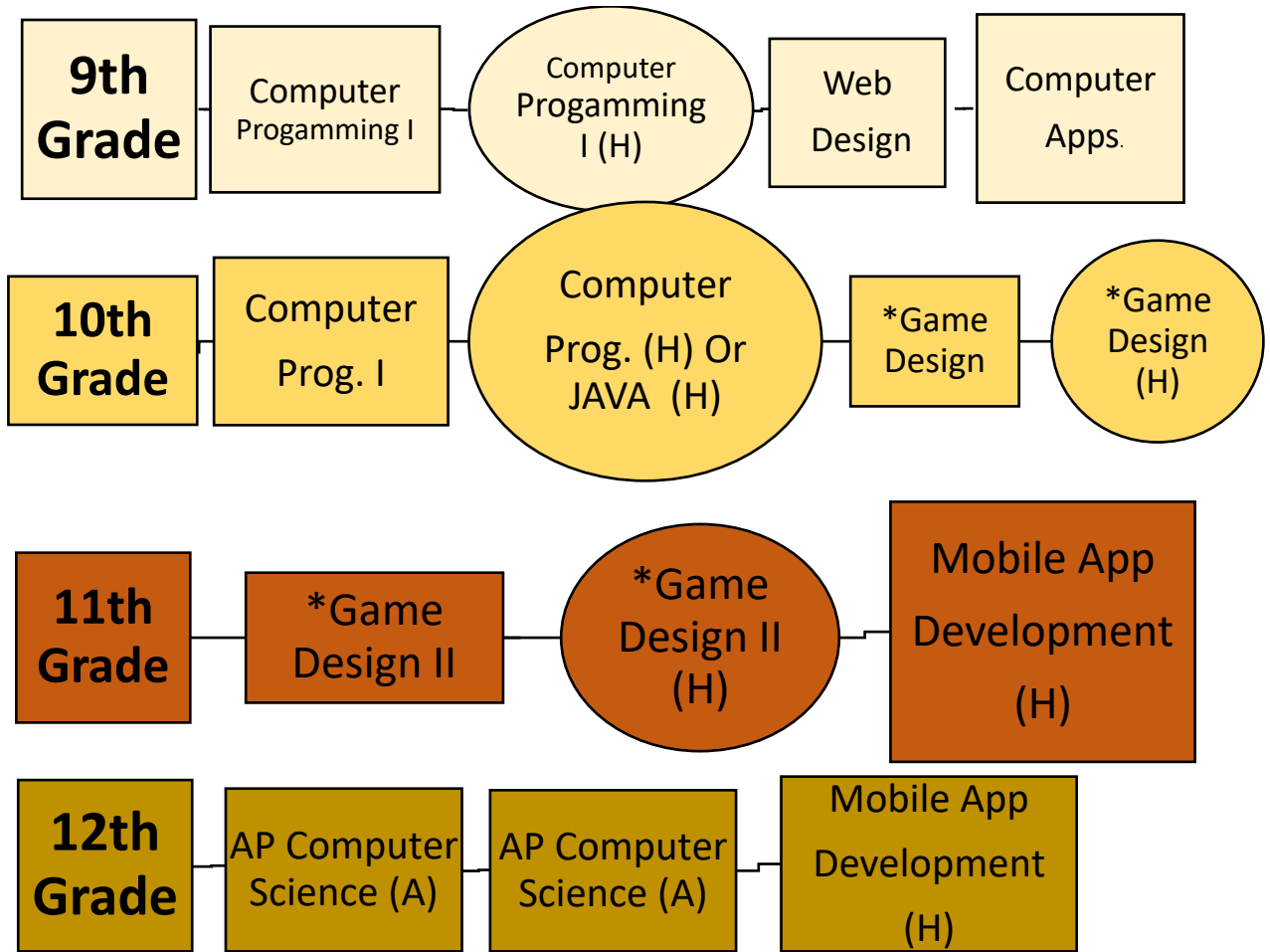

All Technology courses meet graduation requirements for 21st Century Life and Careers Education. Courses with (*) also meet Visual/Performing Arts requirements.

Course #: 4040

Level: II

Grade/s: 9-10-11-12

Credits: 5

Course Title: **COMPUTER PROGRAMMING I**

Description: This course is designed for students who want to learn the art computer programming. Students will be taught to code using the Visual Studio C# and Python

programming languages, which will be used to develop and write programs and problem solve.

Prerequisites: The student must have a basic knowledge of 8th grade Mathematics or must have passed (or is taking concurrently) HS Algebra I

Course #: 4041

Level: III

Grade/s: 9-10-11-12

Credits: 5

Course Title: **COMPUTER PROGRAMMING I (HONORS)**

Description: This course is designed for students who want to learn the art computer programming. Students will be taught to code using the Visual Studio C# and Python programming languages, which will be used to develop and write programs and problem solve. The Computer Programming I Honors course will progress at an accelerated rate and will examine the language at a more in-depth level.

Prerequisites: Either a 'C' or better in Honors 8th grade Mathematics or a 'C' or better in HS Algebra I (can be taken concurrently).

Course #: 4042

Level: II

Grade/s: 9-10-11-12

Credits: 5

Course Title: **WEB DESIGN**

Description: This course is structured for the computer science student who wishes to pursue the study of designing web pages. Students will create and publish web pages using both web authoring tools and pure HTML code. Students will also learn and use the JavaScript programming language, in addition to other client-server languages, such as PHP.

Course #: 4045

Level: II

Grade/s: 10-11-12

Credits: 5

Course Title: **COMPUTER PROGRAMMING II**

Description: This course is a continuation of the Computer Programming I course. The students will be reintroduced to the Advanced features of the Visual Studio C# and Python programming language, and will study the use of controls, methods, multiple forms and the object-oriented paradigm as it applies to those languages. Honors Computer Programming II will progress at an accelerated pace and will examine the languages at a more in-depth level

Prerequisites: Computer Programming I with a grade of 88 or higher

Course #: 4046

Level: III

Grade/s: 10-11-12

Credits: 5

Course Title: **COMPUTER PROGRAMMING II (HONORS)**

Description: This advanced standing course is a continuation of the Computer Programming I course. The students will be reintroduced to the Advanced features of the Visual Basic and Python programming language, and will study the use of controls, methods, multiple forms and the object-oriented paradigm as it applies to those languages. After the first marking period, the students will be introduced to the C# Programming language. Honors Computer Programming II will progress at an accelerated pace and will examine the languages at a more in-depth level

Prerequisites: Must satisfy the Honors prerequisite. Computer Programming I Honors with a grade of 88 or higher.

Course #: 4076
Level: III
Grade/s: 11-12
Credits: 5

Course Title: **JAVA PROGRAMMING (HONORS)**

Description: Students in the Java Programming course will be exposed to the design and implementation of classes and applications using the Java programming language. Object oriented concepts will be presented throughout. Students will include basic graphical user interface elements in their programs and incorporate their code into web apps and mobile apps.

Prerequisite: Junior or Senior status only. Must satisfy the Honors prerequisite. Computer Programming I with a grade of 88 or higher. Transfer students can take this course upon presentation of a portfolio of previous computer programming work.

Course #: 4077
Level: III
Grade/s: 11-12
Credits: 5

Course Title: **MOBILE APP DEVELOPMENT (HONORS)**

Description: Mobile App Development is an advanced course that will teach computer programming students how to develop and build apps for both the iOS (iPhone) platform and the Android platform. Course topics include interface design, coding in the iOS and Android programming languages, app deployment, handling persistent data, and accessing external data from web services.

Prerequisites: Must satisfy the Honors prerequisite. Computer Programming II with a grade of 88 or higher or Java Programming with a grade of 88 or higher.

Course #: 4100
Level: II
Grade/s: 10-11-12
Credits: 5

Course Title: **COMPUTER PROGRAMMING FOR GAME DESIGN I**

Description: This course is designed to complement the Game Design Curriculum. In addition to studying advanced concepts of programming languages, student will design and write 2D and 3D dimensional games and will program components found in

computer games. Students will study random number generation, collision detection, 2D and 3D graphics, and computer object movement.

Prerequisite: A minimum grade of 88 in Computer Programming 1, or Computer Programming 2 with a minimum grade of 88.

Course #: 4105

Level: III

Grade/s: 10-11-12

Credits: 5

Course Title: **COMPUTER PROGRAMMING FOR GAME DESIGN I (HONORS)**

Description: This honors-level course is designed to complement the Game Design Curriculum. In addition to studying advanced concepts of programming languages, student will design and write 2D and 3D dimensional games and will program components found in computer games. Students will study random number generation, collision detection, 2D and 3D graphics, and computer object movement.

Prerequisite: A minimum grade of 88 in Computer Programming 1 Honors, or Computer Programming 2 Honors

Course #: 4106

Level: II

Grade/s: 11-12

Credits: 5

Course Title: **COMPUTER PROGRAMMING FOR GAME DESIGN II**

Description: This advanced course will focus on building 3D games using advanced software tools. Games created in this course will be of sufficient scope and quality to be uploaded as apps of desktop and mobile devices.

Prerequisite: A minimum grade of 88 in Computer Programming for Game Design I

Course #: 4107

Level: III

Grade/s: 11-12

Credits: 5

Course Title: **COMPUTER PROGRAMMING FOR GAME DESIGN II (HONORS)**

Description: This advanced honors course will focus on building 3D games using advanced software tools. Games created in this course will be of sufficient scope and quality to be uploaded as apps of desktop and mobile devices.

Prerequisite: A minimum grade of 88 in Computer Programming for Game Design I Honors

Course #: 4081

Level: IV

Grade: 12

Credits: 5

Course Title: **AP COMPUTER SCIENCE A**

Description: This Advanced Placement computer science course follows the syllabus provided by the College Board. Topics in this first semester introductory college

course in computer science include programming in Java, programming methodology, including recursion and procedural abstraction. In addition to these topics, the Advanced Placement examination will include algorithms, data structures and data abstraction.

Prerequisite: Java Programming (can be taken concurrently), Student must satisfy all Honors prerequisites.

**ENGLISH
SUGGESTED COURSE SEQUENCES**

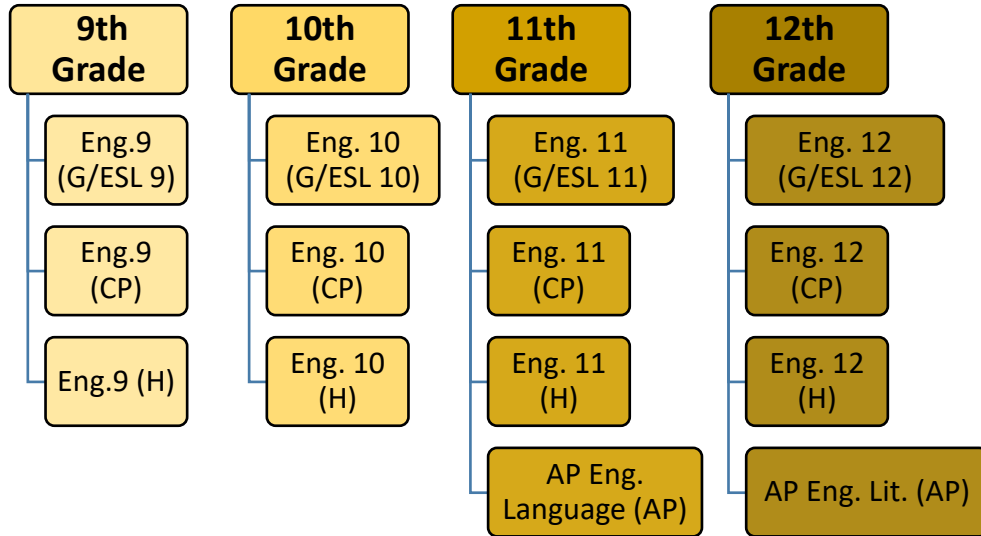

Electives

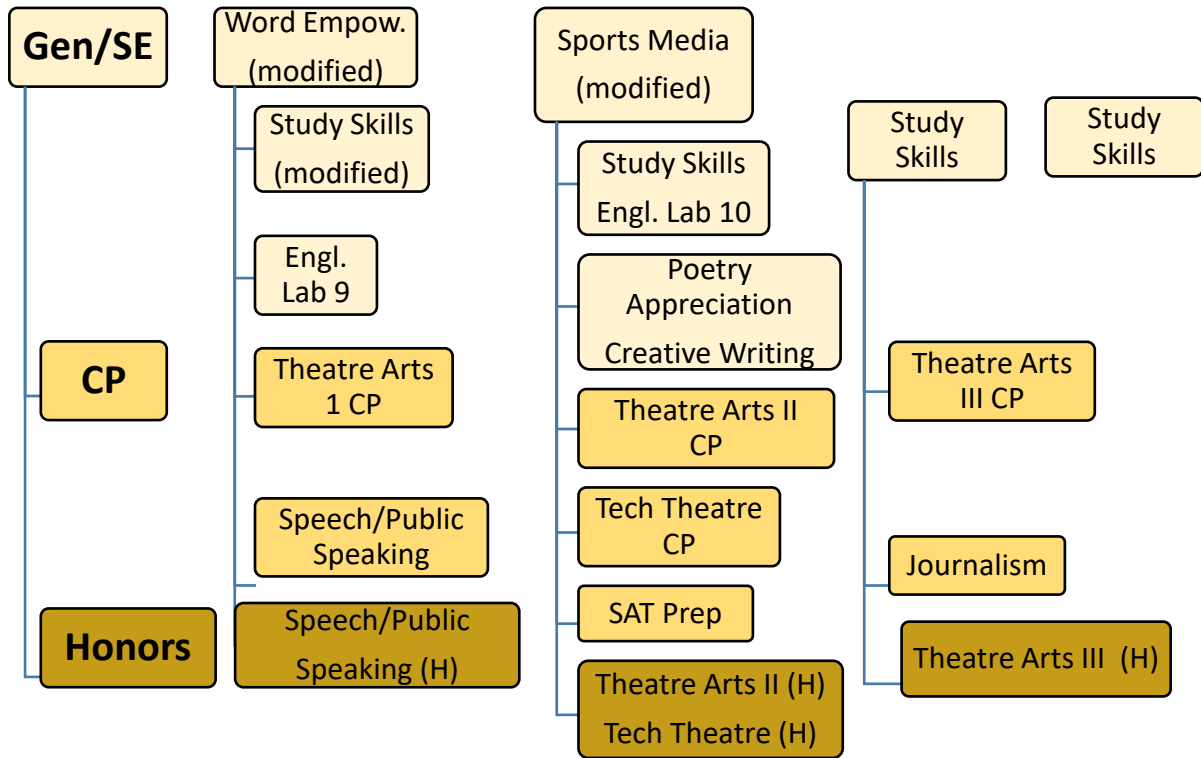

Note: A minimum of 4 years of English (20 credits) are required for graduation.

All students must pass four (4) years of English in order to graduate from a New Jersey high school. Students are not permitted to take English concurrently with another English course during the same school year. At Winslow Township High School, these courses have several designations: the grade at which the course is offered, and the level of achievement required in grades 9-12, which will be Level IV (Advanced Placement), Level III (Honors), Level II (College Preparatory), Level I (General/Introductory/Remedial/Special Education-Modified). Students in the Advanced Placement, Honors and College Preparatory levels are expected to work with greater independence and do more extensive reading and writing activities than students in the General/Introductory levels. Honors and Advanced Placement courses have both academic and achievement pre-requisites. To enroll in an honors course, students must earn a final course grade of 87 or better in a previous college prep course, in the appropriate course sequence and/or the previous course teacher's recommendation. To enroll in an honors course from a previous honors course, students must earn a final grade of 83 or better in the previous honors course, in the appropriate course sequence and/or the previous course teacher's recommendation. To enroll in an Advanced Placement course, students must have earned a final grade of 87 or better in a previous honors course or a final course grade of 92 in a previous college prep course, in the appropriate course sequence and the previous course teacher's recommendations. Summer Reading:

All students must complete a summer reading assignment. Assessment will be made of the summer reading when all students return to class in September.

Course #: 2035

Level: III

Grade: 9

Credits: 5

Course Title: **ENGLISH 9 - Honors**

Description: The course content is based on evaluation and analysis of various literary forms, including Shakespeare's *Romeo and Juliet*. Emphasis is placed on higher-level thinking skills, integration of knowledge and product-oriented projects. The purpose of the course is to provide advanced language arts experiences and opportunities for students who have mastered the individual reading, writing and speaking skills at the seventh and eighth grade levels.

Prerequisite: Students must achieve an 87 or higher in a previous CP English course to enroll in this course.

Course #: 2040

Level: II

Grade: 9

Credits: 5

Course Title: **ENGLISH 9 - College Preparatory**

Description: The course content is based on application of reading, writing and speaking skills that have been introduced and/or mastered at the eighth-grade level. Levels of investigation and evaluation are stressed. Curriculum is taught through use of the short story, essay, drama, novel and poetry, and includes Shakespeare's *Romeo and Juliet*. Many projects are product oriented.

Course #: 2045

Level: I

Grade: 9

Credits: 5

Course Title: **ENGLISH 9**

Description: This course is designed to improve students' skills in reading and writing as determined by standardized test. It is designed for the student who is seeking to improve his/her skills and to prepare for enrollment in a two-year college program, to pursue career training, or to enter the workplace. Emphasis is placed on meeting the individual needs of students through diagnosis and remediation of skills.

Course #: 2055

Level: I

Grade: 9

Credits: 5

Course Title: **ENGLISH 9 - Modified**

Description: This course will concentrate on developing a student's basic communication skills. The purpose of this course is to reinforce specific speaking, composition and reading skills, grammar usage and research techniques. The curriculum

will be appropriately modified by varying teaching techniques, strategies and materials to meet the educational needs of special education students as reflected in their Individual Education Program.

Course #: 2481

Level: I

Grade/s: 9-10-11-12

Credits: 5

Course Title: **WORD EMPOWERMENT - Modified**

Description: This course is designed to teach the skills necessary for successful reading comprehension. Through the Word Empowerment course students will be provided with the strategies and techniques that are essential in decreasing the effort to read for comprehension. The student will be an active participant in the reading process in selecting reading for pleasure in a supportive, non-threatening environment. The curriculum will be appropriately modified by varying teaching techniques, strategies and materials to meet the educational needs of special education students as reflected in their Individual Education Program.

Course #: 2482 / 2483 / 2484 / 2485

Level: I

Grade/s: 9-10-11-12

Credits: 5

Course Title: **STUDY SKILLS I, II, III, IV - Modified**

Description: This course seeks to prepare the special needs student to become an independent and responsible learner. Instruction will focus on notetaking, organizational, and reference skills. The curriculum will be appropriately modified by varying teaching techniques, strategies and materials to meet the educational needs of special education students as reflected in their Individual Education Program.

Course #: 2135

Level: III

Grade: 10

Credits: 5

Course Title: **ENGLISH 10 - Honors**

Description: This course will expand the student's proficiency in English skills. Intensive vocabulary development will continue with additional activities including roots, affixes and analogies. The reading material includes selected works of literature, including Shakespeare's Julius Caesar, with a focus on the study of the various literary forms. Written composition activities will concentrate on paragraph and essay development through a variety of types and methods. Students will be able to understand how to express themselves clearly and effectively.

Prerequisite: A grade of 87 or better in the previous College Preparatory course or a grade of 83 or better in the previous Honors course.

Course #: 2140
Level: II
Grade: 10
Credits: 5

Course Title: **ENGLISH 10 - College Preparatory**

Description: This course will seek to develop greater student proficiency in basic skills of English grammar, usage and vocabulary. It is designed for the student who is seeking to improve his/her skills and to prepare for enrollment in a two-year college program, to pursue career training, or to enter the workplace. Additional skill areas will include library research, study and organizational skills, listening, speaking and critical thinking. Activities in literature will include introductory study of literary forms including short story, poetry, essay, drama and the novel. Students will also read and analyze Shakespeare's Julius Caesar.

Course #: 2145
Level: I
Grade: 10
Credits: 5

Course Title: **ENGLISH 10**

Description: This course will continue with the development of the student's basic skills of grammar, usage and vocabulary. Drill activities will be used to eliminate common errors and strengthen individual reading and writing skills. Students will work on developing composition skills and will practice basic research methods. Types of literature studied are: short story, poetry, and drama. The selections will focus on practical situations and easily identified personalities. It is designed for the student who is seeking to improve his/her skills and to prepare for enrollment in a two-year college program, to pursue career training, or to enter the workplace.

Course #: 2155
Level: I
Grade: 10
Credits: 5

Course Title: **ENGLISH 10 - Modified**

Description: This course will continue with the development of the student's basic communication skills. A strong emphasis will be placed on grammar usage and vocabulary. Special strategies will be utilized to strengthen reading and writing skills. The curriculum will be appropriately modified by varying teaching techniques, strategies and materials to meet the educational needs of special education students as reflected in their Individual Education Program.

Course #: 232000

Level: IV

Grade: 11

Credits: 5

Course Title: **ENGLISH LANGUAGE and COMPOSITION English AP (Advanced Placement)**

**Eligible for college credits from Rowan College at Burlington County- listed as College Composition I

Description: The eleventh grade English Advanced Placement course is designed for students who are interested in studying analytic literature and writing various kinds of argumentative essays on non-literary topics. This course challenges students in becoming skilled readers of prose written in a variety of rhetorical contexts, and in becoming skilled writers who compose for a variety of purposes. Writing and reading activities will aid in the students understanding of the writer's purposes, audience's expectations, and subjects, as well as the way genre conventions and the resources of language contribute to effectiveness in writing.

Prerequisite: A grade of 87 or better in the previous Honors Course or a 92 or better in the previous College Preparatory course.

Course work would be written so that students could earn Camden County College credit pending results of the Advanced Placement Test.

Course #: 2235

Level: III

Grade: 11

Credits: 5

Course Title: **ENGLISH 11 - Honors American Literature**

Description: This course will center on the study of major writers and genres of American literature. The students will concentrate on critical analysis of literature and responding to the literature in standard critical form. In addition, students will read and analyze Shakespeare's Hamlet. Intensive vocabulary work will be included in the course. Grammar will be studied in conjunction with composition and research skills. Writing activities will concentrate on the writing of full-length compositions which develop a thesis statement. Various reports and research papers, and SAT preparation activities, are required course work.

Prerequisite: A grade of 87 or better in the previous College Preparatory course or a grade of 83 or better in the previous Honors course.

Course#: 2240

Level: II

Grade: 11

Credits: 5

Course Title: **ENGLISH 11 – College Preparatory American Literature**

Description: This course will continue to develop needed college preparation skills of English grammar, usage, SAT preparation, style and literacy vocabulary. Written activities will include many compositions, essays and formal research papers. The literary focus of this course will survey several periods of American Literature. Students

will study various authors and their works and be asked to communicate their reactions through discussions, writing assignments and tests. Attention will also be given to the works of several great American authors and an analysis of what constitutes literacy “greatness”. In addition, students will read and analyze Shakespeare’s Hamlet. A good English vocabulary and writing ability will be required of students in this course. Prerequisite: Successful completion of the English 10 and 50 high school credits is recommended.

Course #: 2245

Level: I

Grade: 11

Credits: 5

Course Title: **ENGLISH 11 (General) American Literature**

Description: This course will focus on English Language Arts graduation requirements. Course content will review and reinforce earlier skill development in the area of English grammar and usage. It is designed for the student who is seeking to improve his/her skills and to prepare for enrollment in a two-year college program, to pursue career training, or to enter the workplace. The purpose of writing will be to help students to correct common writing errors and eliminate areas of weakness. The students will be involved in the study of selected stories, plays, and poems that focus on American authors.

Course #: 2255

Level: I

Grade: 11

Credits: 5

Course Title: **ENGLISH 11 - Modified**

Description: This course will involve the student in practical career-oriented skills. Students will be introduced to various stories, plays and poems. Report projects, book reports, and an oral report are required by the course. The curriculum will be appropriately modified by varying teaching techniques, strategies, and materials to meet the educational needs of special education students as reflected in their Individual Education Program.

Course #: 2330

Level: IV

Grade: 12

Credits: 5

Course Title: **LITERATURE & COMPOSITION ENGLISH 12 AP (Advanced Placement)**

**Eligible for college credits from Rowan College at Burlington County- listed as College Composition II

Description: The twelfth grade English Advanced Placement course follows the syllabus provided by the Winslow High School English Teacher approved by the College Board. The AP examination tests the student’s ability to read selected poems and prose passages analytically and to write critical or analytical essays based on poems, prose passages, and complete novels and/or plays.

Prerequisite: A grade of 87 or better in the previous Honors Course or a 92 or better in the previous College Preparatory course.

Course #: 2335
Level: III
Grade: 12
Credits: 5

Course Title: **ENGLISH 12 – Honors British Literature**

Description: This course emphasizes a survey of British literature from the Anglo-Saxon era to modern times. Stress is placed on analyzing historical background and literary genre. The student will be exposed to classic examples of poetry, drama, novels and satire, writing, and Shakespeare's Macbeth. Research and composition skills will be practiced extensively. Reading and writing skills will be necessary to cope with more challenging and sophisticated materials.

Prerequisite: A grade of 87 or better in the previous College Preparatory course or a grade of 83 or better in the previous Honors course.

Course #: 2340
Level: II
Grade: 12
Credits: 5

Course Title: **ENGLISH 12 British Literature – College Preparatory**

Description: This course will include a study of the chronological development of British literature, including Shakespeare's Macbeth. Representative works from different periods and authors will be read and reviewed. The literature will be used to stimulate student writing and reading skills. Research and composition activities will be practiced; outside reading will be regularly assigned.

Course #: 2345
Level: I
Grade: 12
Credits: 5

Course Title: **ENGLISH 12 British Literature - General**

Description: This course is designed for the student who is seeking to improve his/her skills and to prepare for enrollment in a two year college program, to pursue career training, or to enter the workplace. This course will include reading and writing skills applied through a survey of British Literature. Vocabulary enrichment, essay writing, book reports and grammar will be emphasized. Discussion activities and supplemental reading will enhance the regular classroom activities.

Course #: 2355
Level: I
Grade: 12
Credits: 5

Course Title: **ENGLISH 12 - Modified**

Description: This course will review reading and writing skills. Emphasis will be placed on tax forms, business and personal letters, employment application forms and

resumes. Oral reports, creative writing and book reports will be emphasized. The curriculum will be appropriately modified by varying teaching techniques, strategies and materials to meet the educational needs of special education students as reflected in their Individual Education Program.

Course #: 2440
Level: II
Grade/s: 9-10-11-12
Credits: 5

**Eligible for college credits from Rowan College of South Jersey- listed as Journalism 1

Course Title: **JOURNALISM**

Description: This introductory course provides a general overview of the field of journalism as well as the skill and knowledge required for good reporting with a wide variety of story types. Units include effective reporting, journalistic vocabulary and parts of a newspaper. Additionally, students will be required to research and write effective news stories. Students will be expected to contribute to the school newspaper as provided. This course may not be taken in place of required English courses.

Course #: 2445
Level: II
Grade/s: 10-11-12
Credits: 2.5 - Semester Course

Course Title: **CREATIVE WRITING**

Description: This course is aimed at helping students make keener and more sensitive observations of life, to provide a medium for self-expression and to enhance and develop writing talent. Writing activities are varied and challenging and cover the use of figurative language, the writing of short stories, short plays and poetry. Students will be expected to contribute to any in house publication. This course may not be taken in place of required English courses.

Prerequisite: English 9

Course #: 2431
Level: I
Grade/s: 9-10-11-12
Credits: 5

Course Title: **SPORTS MEDIA - Modified**

Description: This course will present biographies of sports figures and fiction based in sports settings. Life in sports will be portrayed further through stories, essays and poems. The sports personalities who will be discussed include a wide variety of professional athletes in competition today or major "heroes" of the recent past. Current controversies in sports will be examined as they appear in various media. This course may not be taken in place of the required English courses. The curriculum will be appropriately modified by varying teaching techniques, strategies and materials to meet the educational needs of special education students as reflected in their Individual Education Program.

Course #: 2425
Level: II
Grade/s: 9-10-11-12
Credits: 5

Course Title: **SPEECH AND PUBLIC SPEAKING**

Description: This course is designed to help the student understand the fundamentals of oral communication. The students will develop self-confidence through their ability to prepare and deliver talks and speeches, including demonstrations, informative and persuasive speeches. Effective discussion techniques will also be stressed. Some specific characteristics of effective speech making will be considered including appearance, bodily expression, voice tone, speech habits and general organization. This course may not be taken in place of the required English courses.

Course #: 2426
Level: III
Grade/s: 9-10-11-12
Credits: 5

Course Title: **SPEECH AND PUBLIC SPEAKING HONORS**

Description: This course is designed to help the student understand the fundamentals of oral communication. The students will develop self-confidence through their ability to prepare and deliver talks and speeches, including demonstrations, informative and persuasive speeches. Effective discussion techniques will also be stressed. Some specific characteristics of effective speech making will be considered including appearance, bodily expression, voice clarity, speech habits and general organization. This course may not be taken in place of the required English courses. This course will include an in-depth examination of classical principles of rhetoric, effective persuasive techniques as well as an exposure to primary source material taken from history's great speeches.

Prerequisite: A grade of 87 or better in the previous College Preparatory English course or a grade of 83 or better in the previous Honors English course.

Course #: 2495
Level: II
Grade/s: 10-11-12
Credits: 2.5 Semester

Course Title: **SAT PREP**

Description: SAT PREP is designed to help students maximize their scores in the critical thinking and math sections of the SAT through daily application and practice with the techniques and concepts assessed on the exam.

Prerequisite: Geometry or Integrated Geometry or currently enrolled in Geometry or Integrated Geometry.

Course #: 2205
Level: II
Grade/s: 9-10-11-12
Credits: 5

Course Title: **THEATRE ARTS I**

Description: This theatre course is designed to provide the student with a strong background in theatre by reading a variety of plays studying the history of acting and theatre, participating in improvisational theatre exercises and activities, acting and directing scenes, monologues, and plays, and participating in an actual theatre production. The students not only will become knowledgeable in the many aspects of theatre, but also will develop invaluable oral communication skills.

Course #: 2405 / 2406
Level: II / III
Grade/s: 9-10-11-12
Credits: 5

Course Title: **THEATRE ARTS II / THEATRE ARTS II Honors**

Description: This course more deeply explores the styles and types of drama, and history of the theatre, playwriting, directing, acting and play production. Public speaking, storytelling, writing and creating plays are also studied and emphasized. The student will be involved in more extensive play production by applying technical skills and training in acting and directing in the production of one-act plays and other theatrical productions. The honors component of this course is designed to further hone students' acting, directing, playwriting, and play production skills, as well as, broaden their knowledge of plays and playwrights.

Prerequisite: (For Theatre Arts II) Theatre Arts I and/or theatre teacher recommendation; (for Theatre Arts II Honors) 87 or higher in Theatre Arts I.

Course #: 2470 / 2475
Level: II / III
Grade/s: 10-11-12
Credits: 5

Course Title: **THEATRE ARTS III -CP/THEATRE ARTS III - Honors**

Description: This course is an advanced level theatre course which extends the students previously acquired theatrical knowledge and skills. Students will study the art of directing theatrical productions. They will demonstrate a higher proficiency in playwriting, directing, acting, technical theatre, play production through theatrical presentations, their playwriting and workshops. Students may work with elementary and/or middle school level students, as well as presenting their work for them. The honors component of this course is designed to further hone students' acting, directing, playwriting and play production skills, as well as, broaden their knowledge of plays, playwrights, and the historical eras in which the plays were written.

Prerequisite: Theatre Arts III (CP): Theatre Arts II and/or theatre teacher recommendation; Theatre Arts III Honors: Grade of 87 or higher in Theatre Arts II.

Course #: 2480 / 2481

Level: II / III

Grade/s: 10-11-12

Credits: 5

Course Title: **TECHNICAL THEATRE / Honors**

Description: This course is an advanced level course for students to demonstrate proficiency in production design through the application of technical knowledge and skills. The student will design, produce and present plays. Technical design of the set of a production will be emphasized rather than acting and directing. Also, students will study the art of puppetry and design, write and produce their own puppet plays. Students may work with and/or present their plays to elementary school and middle school students. The honors component of this course is designed to further hone the students' technical and design skills, as well as, broaden their knowledge of the history of set and technical design.

Prerequisite: Theatre Arts I and/or theatre teacher recommendation. Honors prerequisite for Technical Theatre Honors.

Course #: 2434

Level: II

Grade/s: 10-11-12

Credits: 2.5 – Semester Course

Course Title: **POETRY APPRECIATION**

Description: Poetry Appreciation is designed for students who enjoy recording their life experiences in writing, during moments of inspiration and imagination. Emphasis will be placed on exploring, developing and using literary technique in various poetry assignments. Students will be asked to read a variety of classic and contemporary poetry. They will reflect and analyze famous works and student written poetry, along with composing their own poetry.

Prerequisite: English 9

Course #: 205533 / 215533

Level: I

Grade/s: 9-10-11-12

Credits: 5

Course Title: **ENGLISH 9/10 LAB**

Description: This course directly addresses individual needs through differentiated instruction, adaptive and instructional software, high-interest literature, and direct instruction in reading, writing, and vocabulary skills. Students must test out to exit this program.

Course #: 2500 / 2501 / 2502 / 2503

Level: I

Grade/s: 9-10-11-12

Credits: 5

Course Title: **ENGLISH AS A SECOND LANGUAGE (ESL)**

Description: This course is designed to improve oral, reading, and written language skills of students whose native language is not English. Students are placed in this course according to need and will earn a pass/fail grade.

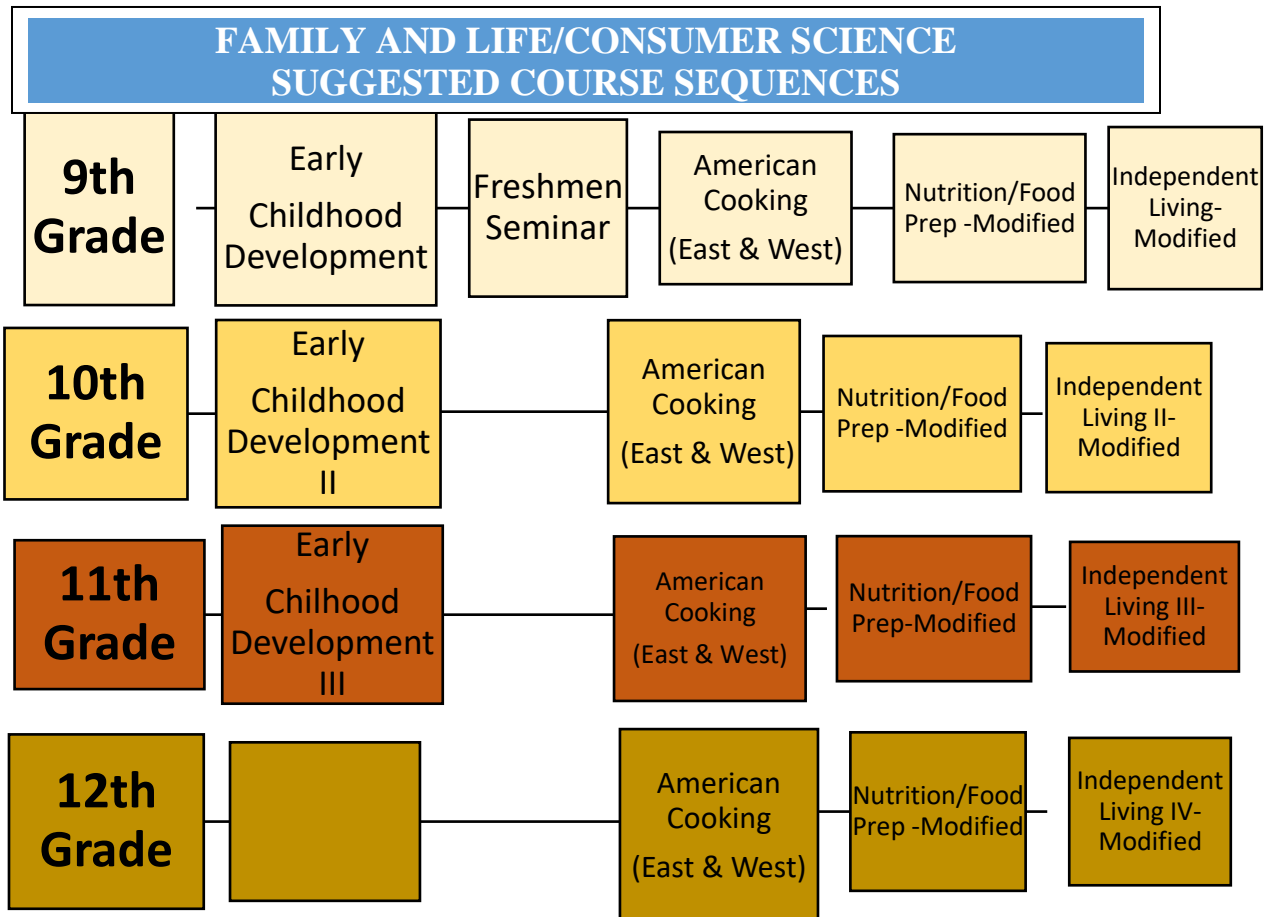

All Family Consumer Sciences courses (full year and semester) meet graduation requirements for 21st Century Life and Careers or Career-Technical Education.

Course #: 4940

Level: I

Grade/s: 9-10

Credits: 5

Course Title: **EARLY CHILDHOOD DEVELOPMENT I**

Description: Early Childhood will help students gain insight and understanding of the developmental milestones of young children. This course is the foundation to qualify for

Early Childhood. It will show how children grow and master new skills in their early years. This class also includes the responsibility and concerns of caring for a child. Students will be required to care for the "Reality Baby" (students would care for the baby for one night only)

Course #: 4943

Level: II

Grade/s: 10-11

Credits: 5

Course Title: **EARLY CHILDHOOD DEVELOPMENT II**

**Eligible for college credits from Camden County College- listed as Children's Health.

Description: This course will show students the responsibilities involved in meeting the physical, cognitive and social/emotional needs of children. Students will also focus on the impact major theorists have had on the development of young children. This course will also focus on the factors that influence child care programs; cost, location, safety, food allergies, children's mental health issues the impact of the environment and training off staff. Students will be required to care for the "mechanical baby" for 72 hours.

Pre-requisite: Early Childhood Development I.

Course #: 4948

Level: II

Grade/s: 11-12

Credits: 5

Course Title: **EARLY CHILDHOOD DEVELOPMENT III**

**Eligible for college credits from Camden County College- listed as Language Arts
PRESCHOOL

Description: This course will provide the planning and preparation of developing a curriculum for young children. Teaching pre-school children will be a part of the hands-on experience. This course will focus on instruction time, lesson plans, observations, creative storytelling, journals and a variety of activities for young children.

Pre-requisite: Early Childhood I and II

Course #: 4987

Level: I

Grade/s: 9-10-11-12

Credits: 2.5 - Semester Course

Course Title: **AMERICAN COOKING - EAST**

Description: Students learn recipe basics and progress to American regional foods. Students will learn how various cultures have influenced American cooking and eating. Students will prepare and serve meals from the New England and Mid-Atlantic regions of the United States. Students will maintain a recipe file and a folder.

Course #: 4988

Level: I

Grade/s: 9-10-11-12

Credits: 2.5 - Semester Course

Course Title: **AMERICAN COOKING - WEST**

Description: This course helps the student to appreciate the different kinds of foods prepared by people in other areas of the United States. These foods are a part of the American menu in fast food and gourmet restaurants. Eight regions, including the South, Mid-West and the West, will be the focus of recipes students will prepare and serve. Students will maintain a recipe file and a folder which will receive a project grade.

Course #: 4496

Level: I

Grades: 9-10-11-12

Credits: 5

Course Title: **NUTRITION/FOOD PREP - Modified**

Description: This course will help the student understand healthy eating and incorporate it into their personal lives. The primary objective is for students to learn how to prepare healthy meals and snacks. They will learn how to read labels, count calories for nutritional information, learn how to use kitchen tools and measure, and adapt recipes for healthier choices. Student will also learn how to shop for food and supplies. Class size is limited and by selection only. The curriculum will be appropriately modified by varying teaching techniques, strategies and materials to meet the educational needs of special education students as reflected in their Individual Education Program.

Course#: 4971 / 4976 / 4977 / 4978

Level: I

Grade/s: 9-10-11-12

Credits: 5

Course Title: **INDEPENDENT LIVING I, II, III, IV – Modified**

Description: This course seeks to prepare the student to adapt to life after high school and includes a large range of knowledge and skills believed to be essential to independent adult living. The students will learn a variety of skills relevant to living on their own, daily living, personal/ social skills, and occupational skills. Topics that will be emphasized include maintaining a household, cleaning, cooking, laundry, shopping, job seeking, career research and planning, money management, banking, credit and housing. Students will also develop skills in decision-making, problem solving, relationships and social responsibilities. Class size is limited and is for selected students only. The curriculum will be appropriately modified by varying teaching techniques, strategies and materials to meet the educational needs of special education students as reflected in their Individual Education Program.

Course#: 4900

Level: I

Grade: 9

Credits: 2.5

Course Title: **FRESHMEN SEMINAR**

Description: This is a required course for all first-year incoming freshmen. This course will optimize the high school experience by utilizing a multimedia curriculum designed to improve high school students' social, emotional, and academic skills and strengthen relationships among students and between students and teachers, as well as to build students' college and career readiness skills.

The program consists of three modules based on the Social and Emotional Learning Competencies identified as critical to success in school, the workplace, and life in general: social awareness, self-awareness, self-management, relationship skills, and responsible decision making.

This is a graded semester course that does not get calculated into the student’s grade point average (GPA).

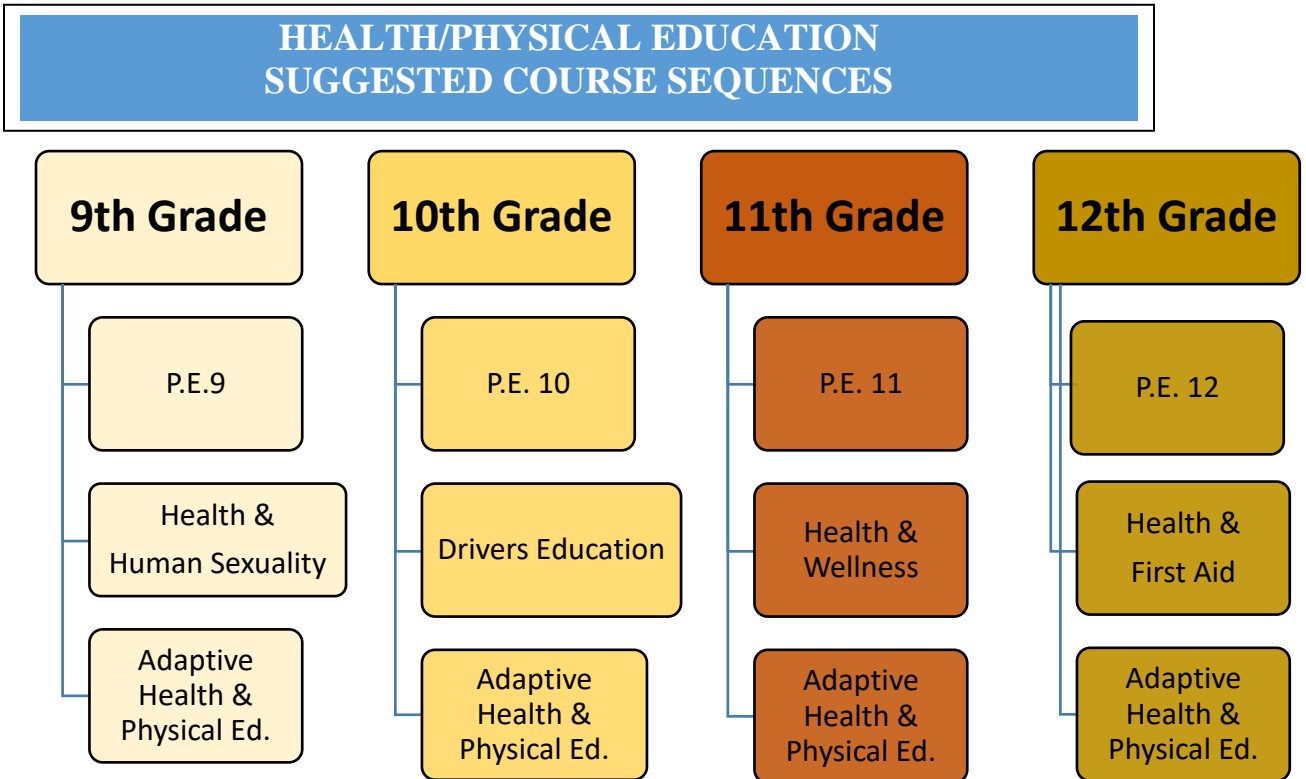

INTRODUCTION: All students are reminded that they must meet the dress requirements for physical education classes that are outlined in the Student Handbook. Student grades may be impacted by failure to follow the dress code requirements for physical education classes.

Course #: 6030
 Level: I
 Grade: 9
 Credits: 5
 Course Title: **HEALTH/HUMAN SEXUALITY / PHYSICAL EDUCATION 9**

Description: Ninth grade health will focus on the promotion of healthier lifestyles. Human sexuality will include relationships, puberty, physical and emotional changes, male and female reproductive systems, abstinence, birth control methods, prevention of sexually transmitted diseases, pregnancy and childbirth. The reality of marriage and family are also explored. The Physical Education program involves skills and game

theory in team sports, individual and dual sports, rhythms, fitness and strength development.

Course #: 6035
Level: I
Grade: 10
Credits: 5

Course Title: **DRIVER EDUCATION AND PHYSICAL EDUCATION 10**

Description: The health segment of this course deals primarily with automobile safety. The student will learn to develop the proper attitude, appreciation and understanding essential to safe, sane, cooperative use of the streets and highways in the State of New Jersey. Also stressed are the dangers of operating a car while under the influence of alcohol and/or drugs. All students will be taking the Written Exam for their New Jersey's Driver's Permit. Basic physical skills and testing of these skills are introduced in this course. Physical fitness is improved through exercises and testing. Rules and regulations are taught for various sports.

Course #: 6040
Level: I
Grade: 11
Credits: 5

Course Title: **HEALTH AND WELLNESS/ PHYSICAL EDUCATION 11**

Description: This unit will explore overall health and total wellness with special emphasis on contemporary nutrition and fitness. Topics will include prevention of eating disorders, alternative eating in today's society, increasing physical activity, sports nutrition, body image and special nutritional problems affecting adolescents. The objective of Physical Education is to provide a review of the basic rules, skills and strategies in major sports. Students are encouraged to think "physical fitness" and implement this fitness mentality in daily life. Sportsmanship, team spirit and cooperation are stressed in games and class activities.

Course #: 6045
Level: I
Grade: 12
Credits: 5

Course Title: **HEALTH/FIRST AID AND PHYSICAL EDUCATION 12**

Description: First Aid includes instruction in emergency first aid and current issues in health care. The students will develop skills and knowledge of First Aid treatment in a variety of situations ranging from minor injuries to major emergencies. The students will learn that preparedness, practical skills and sound judgment are the key to the treatment of accidents and illnesses. This course stresses the carry-over value of the sports played in school. Physical activity as a viable and healthy leisure time activity is stressed. Advanced skills and sports strategies are developed further.

Course #: 6030/6035/6040/6045
Level: I
Grade: 9-10-11-12
Credits: 5

Course Title: ADAPTIVE HEALTH & PHYSICAL EDUCATION--Modify

This course is a modification of physical education activities intended to meet the needs of persons with disabilities. Physical education lessons are adapted/modified to meet the individual needs of each student. The adapted physical education teachers work to help students maintain mobility by refining the student's motor skills, balance, flexibility and hand-eye coordination. Social skills are integrated in all activities, and students are encouraged to engage in a variety of modified sport activities. Students will be assigned this course as per their IEP (Individualized Education Plan).

HISTORY AND SOCIAL SCIENCE - SUGGESTED COURSE SEQUENCES

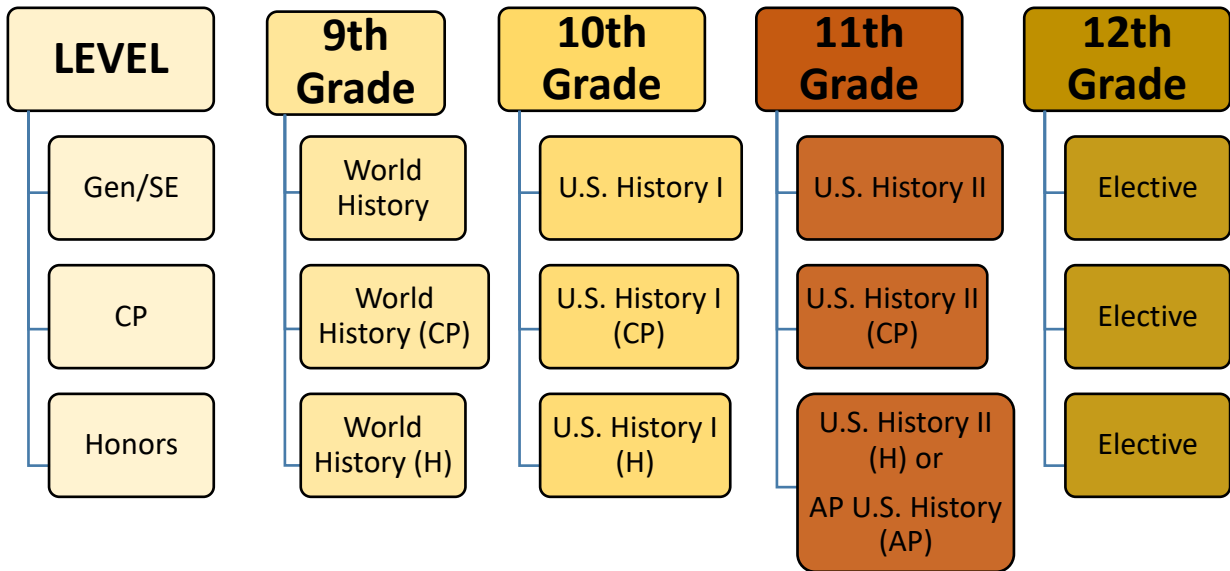

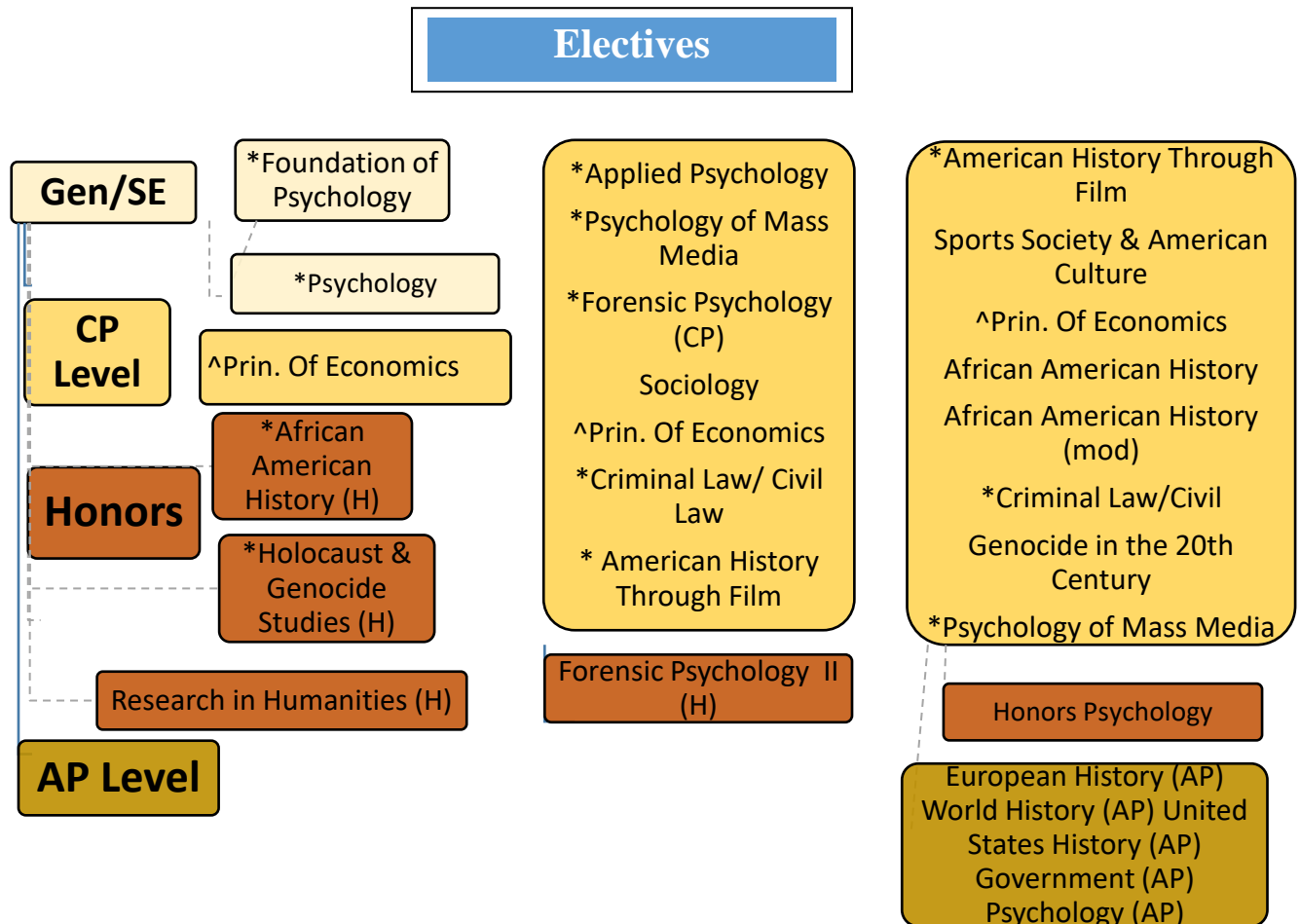

INTRODUCTION: All students are required to take World History, US History I, and US History II to meet graduation requirements. Additional college preparatory courses in social studies are strongly recommended for the academic student.

Course #: 2530
 Level: III
 Grade: 9
 Credits: 5

Course Title: **WORLD HISTORY - Honors**

Description: This is a one-year survey course designed to familiarize the college-bound student who has a serious interest in further education, with the various aspects of world history. These include the geographic, political, economic and social factors of societies. This course will go beyond the typical survey approach by employing the higher level thinking skills of analyzing, evaluating and synthesizing world events and problems.

Prerequisite: Honors criteria recommendation

Course #: 2535

Level: II

Grade: 9

Credits: 5

Course Title: **WORLD HISTORY - College Prep.**

Description: This is a one-year survey course designed to acquaint the student with the geographical, political, economic, social and cultural aspects of world history. The course begins with the development of the Renaissance and continues through to the present time. This course is recommended for the student who is interested in attending college.

Course #: 2540

Level: I

Grade: 9

Credits: 5

Course Title: **WORLD HISTORY**

Description: This one-year survey course is designed to acquaint the student with the geographical, political, economic, social, and cultural aspects of world history. The course begins with the development of the Renaissance and continues through to the present time. This is a basic course which requires students to recognize the most important elements of modern World History. It is designed for the student who is seeking to improve his/her skills and to prepare for enrollment in a two-year college program, to pursue career training or to enter the workplace.

Course #: 2827

Level: IV

Grade/s: 11-12

Credits: 5

Course Title: **AP WORLD HISTORY - (Advanced Placement)**

**Eligible for college credits from Camden County College- listed as World Civilization

**Eligible for college credits from Rowan College at Burlington County- listed as Ancient & Medieval Foundations of World Civilization

Description: This full year AP course follows the syllabus provided by the College Board. The course follows the integration of regional civilizations into a global whole from prehistory to today. Themes include cultural interaction, change and continuity, technology and demography, society and gender, culture and ideas, and political culture and organization. These serve as frameworks for analyzing international contacts between societies in Asia, Africa, the Americas, and Europe. A dual credit option is available from Camden County College. Students are expected to take the AP examination.

Prerequisite: Junior or senior status and must earn at least a 92 or better average in World, US and US II History.

Course #: 2545

Level: I

Grade: 9

Credits: 5

Course Title: **WORLD HISTORY - Modified**

Description: This course is designed to highlight the development of the major cultures and societies in the world. The work of this course is highly individualized and directly related to a student's ability and academic need. The curriculum will be appropriately modified by varying teaching techniques, strategies and materials to meet the educational needs of special education students as reflected in their Individual Education Program.

Course #: 2630

Level: III

Grade/s: 10-11-12

Credits: 5

Course Title: **UNITED STATES HISTORY I -Honors**

Description: The first year of a two-year course requirement, United States History I covers the political, social and economic events, including Amistad, from Early Colonization through and including the Reconstruction Period and industrialization. The honors class requires extensive composition, evaluation, analysis and independent reporting with emphasis on student originality.

Prerequisite: A grade of 87 or better in the previous College Preparatory course or a grade of 83 or better in the previous Honors course.

Course #: 2635

Level: II

Grade/s: 10-11-12

Credits: 5

Course Title: **UNITED STATES HISTORY I - CP**

Description: The first part of a two-year course requirement, United States History I covers the political, social and economic events, including Amistad, from Early Colonization through and including the Reconstruction Period and industrialization. The college prep class is a survey course which requires composition, analysis and independent reporting.

Course #: 2640

Level: I

Grade/s: 10-11-12

Credits: 5

Course Title: **UNITED STATES HISTORY I**

Description: The first part of a two-year course requirement, United States History I covers the political, social and economic events, including Amistad, from Early Colonization through and including the Reconstruction Period and industrialization. This is a basic survey course which requires students to recognize the most important elements of the United States History. It is designed for the student who is seeking to improve his/her skills and to prepare for enrollment in a two-year college program, to pursue career training, or to enter the workplace.

Course #: 2645

Level: I

Grade/s: 10-11-12

Credits: 5

Course Title: **UNITED STATES HISTORY I - Modified**

Description: The first part of a two-year course requirement, United States History I covers the political, social and economic events, including Amistad, from Early Colonization through and including the Reconstruction Period. The curriculum will be appropriately modified to meet the needs of special education students as reflected in their Individual Educational Program.

Course #: 2730

Level: III

Grade/s 10-11-12

Credits: 5

Course Title: **UNITED STATES HISTORY II – HONORS**

Description: The second of a two-year course requirement, United States History II covers the political, social, and economic events from Progressivism through and including the present modern period. The honors course requires extensive composition, evaluation, analysis and independent reporting with emphasis on student originality.

Prerequisite: A grade of 87 or better in the previous College Preparatory course or a grade of 83 or better in the previous Honors course.

Course #: 2735

Level: II

Grade/s: 10-11-12

Credits: 5

Course Title: **UNITED STATES HISTORY II - College Prep.**

Description: The second part of a two-year course requirement, United States History II covers the political, social and economic events from Progressivism, through and including the present modern period. The college prep class is a survey course which requires composition, analysis and independent reporting.

Prerequisite: U.S. History I

Course #: 2740

Level: I

Grade/s: 10-11-12

Credits: 5

Course Title: **UNITED STATES HISTORY II**

Description: The second part of a two-year course requirement, United States History II covers the political, social and economic events from Progressivism, through and including the present modern period. This is a basic survey course which requires that students recognize the most important elements of U.S. History. It is designed for the student who is seeking to improve his/her skills and to prepare for enrollment in a two-year college program, to pursue career training, or to enter the workplace.

Prerequisite: U.S. History I

Course #: 2745
Level: I
Grade/s: 11-12
Credits: 5

Course Title: **UNITED STATES HISTORY II - Modified**

Description: This is the second part of a two-year course requirement that covers the political, social and economic events from Industrialism through and including the present modern period. The curriculum will be appropriately modified to meet the educational needs of special education students as reflected in their Individualized Educational Program.

Course #: 2800
Level: II
Grade/s: 10-11-12
Credits: 5

Course Title: **SOCIOLOGY**

Description: Sociology deals with the investigation of human relationships, and provides a way of understanding human behavior. Sociology deals with the investigation of human relationships and provides a way of understanding human behavior. The course provides students with a comprehensive examination of the basic concepts, principles, and methods central to the scientific study of sociology. Students are given the opportunity to think like sociologists and develop a sociological imagination. The sociological imagination enables students to view their own lives within a larger social and historical context. Students will also be exposed to the rich diversity that is present within societies. This includes cross-cultural materials, data, and a wide variety of historical resources. Students will study group behavior in complex societies as compared to individual behavior studies in the "Psychology" course offering.

Course #: 2803
Level: I
Grade/s: 9-10-11-12
Credits: 5

Course Title: **FOUNDATIONS OF PSYCHOLOGY**

Description: This course will present experiences that will assist the student in making behavior decisions as individuals and members of society. The students will study human behavior in today's society and become increasingly aware in understanding their own behavior and the effect it has on their peers. The students will research such topics as the brain, consciousness, learning, memory, intelligence, human development and social psychology.

Course #: 2805
Level: II
Grade/s: 9-10-11-12
Credits: 5

Course Title: **PSYCHOLOGY**

Description: This course is designed to study human behavior in today's society. Students will become increasingly interested in understanding their own behavior and the effects such behavior has on their peers. The course topics include introduction to those topics provide in the advanced placement psychology course.

Course #: 2806

Level: II

Grade/s: 10-11-12

Credits: 2.5 - Semester Course

Course Title: **APPLIED PSYCHOLOGY**

Description: A career-oriented course that examines the skills, activities and responsibilities of professionals using psychology in applied settings, such as organizations in the business world. A comprehensive study will be made as to how psychology is used, how psychologists do their work and how applications affect daily life. Topics include occupation, engineering and design, space, sport, consumer, and environmental psychology as well as clinical, counseling, health and educational psychology. Experiential learning through the collection and analysis of relevant data will be integrate parts of this course as students consider applications of psychology to learning, perception, personality formation, interviewing, counseling, deviant behavior, vocational selection and the use the test measurements.

Prerequisite: Foundations of Psychology, Psychology.

Course #: 2808

Level: II

Grade/s: 10-11-12

Credits: 2.5

Course Title: **FORENSIC PSYCHOLOGY (CP)**

Description: The various topics of this course will/can include the origins of deviant behavior, what is considered deviant in society, treatments of the deviant individual, professionals involved in the apprehension and treatments, anatomy and physiology of the deviant individual (neural anatomy and anatomy of the endocrine system). The course will also use, as case studies, select individuals whose profiles fit the appropriate topics (serial killers and recidivists).

Prerequisite: Foundations of Psychology or Psychology. Parental permission is required.

Course #: 2815

Level: III

Grade/s: 11-12

Credits: 5

Course Title: **FORENSIC PSYCHOLOGY II (H)**

Description: Forensic Psychology is the study of psychology and its interaction with the legal system. The course applies psychological principles and theories to major issues and topics within the criminal justice system. This advanced course will trace the history of the discipline, discuss the specialties within the field, and different topical issues confronting psychology and the criminal justice field (insanity plea, eyewitness testimony, jury selection, sexual harassment, etc.). Students will also delve into the origin

of criminal and deviant behavior examining the theories that try to explain it, looking at the many biological, cognitive and neurological aspects of criminal behavior.

Prerequisite: A grade of 87 or better in Forensic/Applied Psychology.

Grade/s: 11-12

Credits: 5

Course Title: **AP PSYCHOLOGY - (Advanced Placement)**

**Eligible for college credits from Camden County College- listed as Basic Psychology

**Eligible for college credits from Rowan College at Burlington County- listed as Intro to Psychology

Description: This Advanced Placement course follows the syllabus provided by the College Board. Students' are expected to take the AP examination which tests the students skills and knowledge in the following areas: methods, approaches, and history; biological basis of behavior; sensation and perception; states of consciousness; learning; cognition; motivation and emotion; developmental psychology; personality; testing and individual differences; abnormal psychology; treatment of psychological disorders; and social psychology.

Prerequisite: A grade of 87 or better in Honors or a 92 or better in CP Psychology class.

Course#: 2812

Level: III

Grade/s: 10-11-12

Credits: 5

Course Title: **HONORS PSYCHOLOGY**

Description: Honors Psychology provides an overview of current psychological research methods and theories. Students will explore the therapies used by professional counselors and clinical psychology and examine the reasons for normal human reactions: how people learn and think, the process of human development and human aggression, altruism, intimacy, and self-reflection. They will study core psychological concepts, such as brain and sense functions, and learn to gauge human reactions, gather information, and form meaningful syntheses. Students will also investigate relevant concepts like study skills and information retention. Honors Psychology prepares students for further studies in psychology, such as Advanced Placement Psychology and Developmental Psychology.

Prerequisite: A grade of at least an 83 or better in English.

Course #: 2825

Level: IV

Grade: 12

Credits: 5

Course Title: **AP UNITED STATES HISTORY - (Advanced Placement)**

**Eligible for college credits from Camden County College- listed as US History II

**Eligible for college credits from Rowan College at Burlington County- listed as US History I & II

Description: This Social Studies Advanced Placement course follows the syllabus provided by the College Board. Students are expected to take the AP examination which focuses on United States History from the first European explorations of the Americas to the present. Topics include political institutions and behavior, public policy, social and

economic change, diplomacy and international relations, and cultural and intellectual developments.

Pre-requisite: A grade of 92 or better in the previous College Preparatory course or a grade of 83 or better in the previous Honors course.

This will meet the requirements of US History II.

Course #: 2890

Level: IV

Grade/s: 11-12

Credits: 5

Course Title: **AP GOVERNMENT - (Advanced Placement)**

**Eligible for college credits from Camden County College- listed as American Federal Government

**Eligible for college credits from Rowan College at Burlington County- listed as American National Government and Politics

Description: The goal of the course is to increase understanding of the American political system, its framework, traditions and values, and having each student pass the Advanced Placement Exam. This course is concerned with the nature of the American political system, its development over the past two centuries. We will discuss political ideology, the development of the political system and our democratic institutions. The main thrust of the course, however, is to be able to apply an understanding of our political system to contemporary events. At the conclusion of the course students will have a more sophisticated understanding of majority rule democracy, constitutionalism and civil liberties.

Prerequisite: A grade of 87 or better in the previous Honors Course or a 92 or better in the previous College Preparatory course.

Course #: 2865

Level: II

Grade/s: 10-11-12

Credits: 2.5

Course Title: **AFRICAN AMERICAN HISTORY**

Description: This course offers a balanced view of the African American's past and present. The course has been prepared to correct past distortions and fill in enormous gaps of information concerning the history of the African American. The course will highlight the role and contributions of Americans of African descent in the development of the United States.

Prerequisite: A 'C' or Better in previous History Classes

Course #: 2866

Level: I

Grade/s: 9-10-11-12

Credits: 5

Course Title: **AFRICAN AMERICAN HISTORY – Modified**

Description: This course celebrates the culture and history of African Americans from the Kingdoms of Africa (Pre-exploration) through contemporary issues of today.

Through the study of music, cuisine, dance, art, religion and movies, the students will gain an understanding of the role African Americans played in the history of America. The curriculum will be appropriately modified by varying teaching techniques, strategies and materials to meet the educational needs of special education students as reflected in their Individualized Education Program.

Course #: 2845
Level: II
Grade/s: 10-11-12
Credits: 2.5 - Semester Course
Course Title: **CRIMINAL LAW**

Description: This course provides students with a basic understanding of criminal law and the administration of justice. Students will learn legal terminology, how the police investigate crime, and differences between misdemeanors and felonies, and the role of the courts in the legal system. Students will also have a chance to work on research skills. Students will understand how the law and legal process can affect their lives. An oral report or term paper is required in this course.

Course #: 2846
Level: II
Grade/s: 10-11-12
Credits: 2.5 - Semester Course
Course Title: **CIVIL LAW**

Description: This course provides students with a basic understanding of Civil Law. Tort theory, as developed and applied through court decisions, is explained, and students will also learn the basic law in the areas of negligence, probate, marriage, and family. Students will analyze Supreme Court cases dealing with civil rights, freedom of speech, and school law and gain an understanding of how the law and legal process affect their lives. An oral report or written paper is required in this course. Note: Students wishing to learn law as applied to business, such as contracts, property, credit, insurance, and employment, should consider taking the Consumer Law course offered by the Business Education Department.

Course #: 2870
Level: II
Grade: 12
Credits: 2.5 – Semester Course
Course Title: **AMERICAN HISTORY THROUGH FILM**

Description: This semester course will cover highlights, issues, concepts and concerns throughout American History. Utilizing traditional and creative teaching methods and learning experience will be through viewing discussion and analysis of movies-both educational and popular. There will be an introduction to the period and events of the film. There will be group discussion throughout the film and an assessment after the films.

Prerequisite: Must have completed both US I and US II

Course #: 2871
Level: I
Grade/s: 10-11-12
Credits: 5.0

Course Title: **AMERICAN HISTORY THROUGH FILM - Modified**

Description: This semester course will cover highlights, issues, concepts and concerns throughout American History. Utilizing traditional and creative teaching methods and learning experience will be through viewing discussion and analysis of movies-both educational and popular. There will be an introduction to the period and events of the film. There will be group discussion throughout the film and an assessment after the films. The curriculum will be appropriately modified by varying teaching techniques, strategies and materials to meet the educational needs of special education students as reflected in their Individual Education Program.

Course #: 2835
Level: II
Grade/s: 9-10-11-12
Credits: 2.5 – Semester Course

Course Title: **PRINCIPLES OF ECONOMICS**

Description: This semester course is designed to allow students to think critically about events and processes that shape local, national and global economics. Principles of both micro-economics and macro-economics will be explored including: economic systems, supply and demand, market structure and money and banking. Students will also be involved in a variety of problem-solving cases based on contemporary issues, as well as a stock market game. Students will be able to develop critical thinking skills which improves the ability to make wise decisions about budgeting, spending and investing. **This course meets the Financial Literacy graduation requirement.**

Course #: 2850
Level: II
Grade/s: 10-11-12
Credits: 2.5

Course Title: **GENOCIDE IN 20TH CENTURY**

Description: This semester course offers a look at the history of mass murders in 20th century, specifically genocides. Through the use of media, speakers, and educational opportunities, the factors and conditions which lead to such atrocities will be examined, as well as how they can be avoided. Special focus will be placed on the Holocaust and current happenings in the world in such places as Africa and the Middle East. The course will additionally examine the psychological and sociological effects of such murders and how the world views them.

Prerequisite: A 'C' or Better in previous History Classes

Course#: 2875
Level: II
Grade/s: 11-12
Credits: 2.5 – Semester Course

Course Title: **HISTORY: SPORT, SOCIETY AND AMERICAN CULTURE**

Description: This course examines the development of American sports between the 19th and 20th centuries-how sports have been shaped and have shaped the American culture. Gender, race, ethnicity and class will be our primary touchstones as we use sports as a lens to understand Americas past. Our focus will not be on championships and trophies, but more interested in the larger issues in American history: Development of the American national identity; how sports inform ideas of masculinity femininity; impact of industrialization and urbanization on sports and culture; how racism has shaped sports and society. This course will be built around lectures, films and class discussion. Significant reading and rigorous analysis is expected.

Prerequisites: World History and US History I

Course #: 2950
Level: III
Grade/s: 10-11-12
Credits: 5

Course Title: **AFRICAN AMERICAN HISTORY (H)**

**Eligible for college credits from Stockton University—Listed as Africana Studies
Description: This course traces African American history and culture from the West African roots to twenty-first century developments. Students will study the struggles and triumphs of people of West African descent in the America and consider their efforts to forge an identity within the American mainstream. In particular, Students study the contributions of African-Americans to American civilization in the fields of science, the arts, and humanities. Within a historical context, students will analyze historical sources and sample the rich literature written by African Americans. This course will explore the art and music of African American artists, composers and musicians. Students in the African-American Course will analyze and discuss historical and literary sources. In addition to researching individual topics, they will engage in debates, lead and participate in class discussions and complete other forms of performance assessments.

Prerequisite: A grade of 87 or better in the previous College Preparatory English and History course or a grade of 83 or better in the previous Honors English and History course.

Course #: 2951
Level: III
Grade/s: 10-11-12
Credits: 5

Course Title: **HOLOCAUST and GENOCIDE STUDIES (H)**

**Eligible for college credits from Stockton University—Listed as Holocaust & Genocide

Description: This course is designed to give the student a survey of major genocidal movements throughout the 20th Century and into the present day. It will explore a variety of subjects and philosophical concerns. Topics to be discussed and examined will involve some deep thinking and analysis, as well as the exploration of personal and collective feelings and morals. While this course may not change the views of the participants, it will allow students to empathize and sympathize, and to understand other points of view. The Holocaust will be a major focal point due to its immense importance, but will

encompass about half of the class time. Many other important aspects regarding crimes against humanity will also be explored. Current events will also be analyzed.

Prerequisite: A grade of 87 or better in the previous College Preparatory English and History course or a grade of 83 or better in the previous Honors English and History course.

Course # 2952

LEVEL III

Grades 11-12

Credits 5

Course Title: **RESEARCH IN HUMANITIES--STEAM (H)**

Description: Research in Humanities is a course designed for students who are interested in research. It is designed to allow students the unique opportunity to continue exploring the systematic and scientific study of human behavior and mental processes, while also doing hands-on research that will contribute to the larger scientific research community. As part of the course, students will learn about, practice, and evaluate research methods used by psychologists. Students will conduct their own research based on their knowledge and understanding of research methodology. This course will require critical thinking skills, initiative, responsibility, leadership, and strong written and oral expression

Prerequisites: A grade of 87 or better in the previous College Preparatory English and History course or a grade of 83 or better in the previous Honors English and History course.

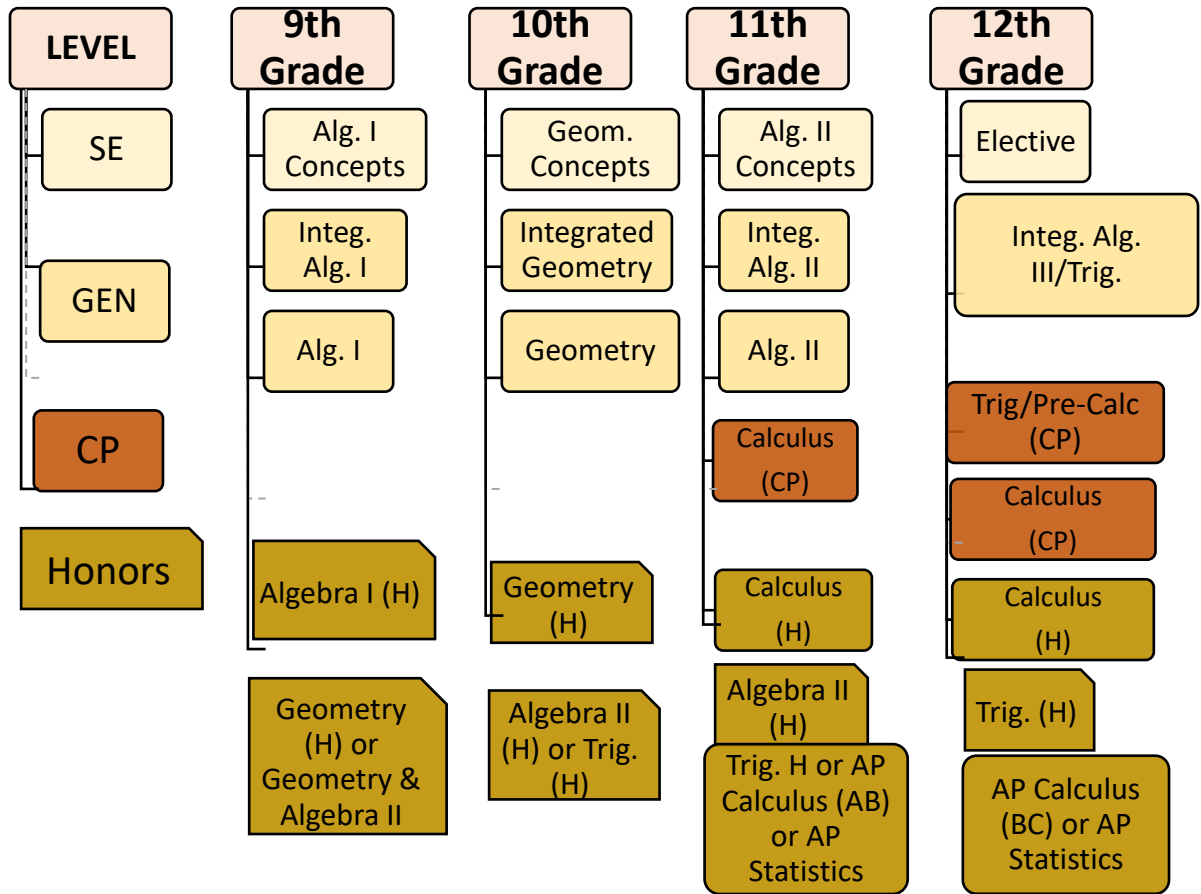

ELECTIVES

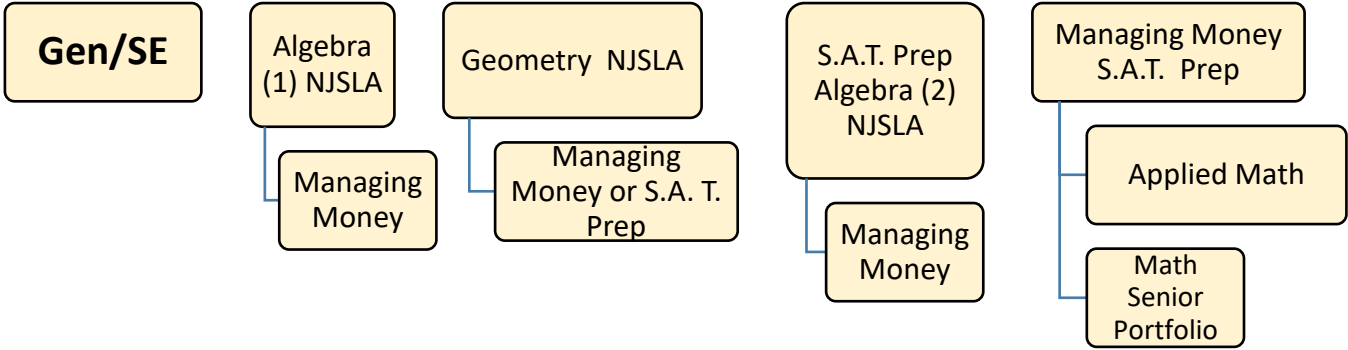

Every freshman must be enrolled in a mathematics course. If they intend to major in mathematics or one of the sciences, they should take as many math courses as possible. The mathematics program at WTHS is a challenging program designed to meet the needs of all students. Programs are available which provide a solid foundation in math concepts and applications, preparing students for college and providing opportunities for

Advanced Placement status. Students who score below proficiency may be placed in Algebra 1 NJSLA LAB and/or Geometry NJSLA LAB courses.

Notes: Placement can be modified based upon teacher recommendation. A minimum of three (3) years or fifteen (15) credits including Algebra I & II and Geometry (or the content equivalent) are required for graduation. Four (4) years of mathematics education is strongly recommended by the National Council of Teachers of Mathematics for success in a technology-oriented world.

INTRODUCTION: Three years of High School mathematics including Algebra I & II and Geometry (or the content equivalent) are required for graduation. Most college-bound students should take four years of mathematics so there is no gap between the last high school mathematics course and the college freshman mathematics course requirements. Any student placed in a Level I mathematics course, because of deficient basic mathematics skills, should successfully complete a Level II course before attempting a Level III course. Note that all placements from grade 8 to 9 are conditional. Final placements will be determined by end of year grades. Students who have completed Algebra Honors in Grade 8 may be accelerated in Grade 9 to Geometry Honors if they have earned a final grade of 80 or better in Algebra Honors, have passed the WTHS Algebra I Honors exam that will be administered to all grade 8 students in Algebra Honors, and have received their teacher's recommendation. Placement in all other mathematics courses will be determined by WTHS AP and Honors placement criteria (page 11).

Course #: 3540
Level: I
Grade: 9
Credits: 5

Course Title: **ALGEBRA I CONCEPTS - Modified**

Description: This course reviews basic mathematics concepts and will develop the student's skills in whole number operations, fractions, decimals, percent's and measurement. This course will introduce algebraic terminology, integers and absolute value. The curriculum will be appropriately modified by varying teaching techniques, strategies and materials to meet the needs of special education students as reflected in their Individual Education Program.

Course #: 3550
Level: II
Grade/s: 9-10
Credits: 5

Course Title: **INTEGRATED ALGEBRA I - (College Preparatory)**

Description: Students who score below the state's minimum level of proficiency on standardized are required to take this course, along with a NJSLA LAB Algebra A. It is designed for the student who is seeking to improve his/her skills and to prepare for enrollment in a two- or four-year college program. It introduces the fundamental topics of Algebra I and Geometry including pattern recognition, basic operations with variables,

measurement of segments, angles and shapes, ratios and proportions, and other foundation concepts. The course reinforces core skills and moves at a more deliberate pace than Algebra I. Students who successfully complete this course may move on to Integrated Geometry or Geometry.

Course #: 3555

Level: II

Grade/s: 9-10-11-12

Credits: 5

Course Title: **INTEGRATED GEOMETRY - (College Preparatory)**

Description: Integrated Geometry covers many of the traditional topics of Algebra I and Geometry including lines and slopes, systems of equations, exponents and polynomials, congruent and similar polygons, and other topics. This course is taken with NJSLA Geometry LAB depending on Link it or NJSLA scores below minimum level. This course also includes fundamental topics in discrete math, and probability.

Prerequisite: Integrated Algebra I or Algebra I

Cannot be taken concurrently with Integrated Algebra II

Course #: 3558

Level: I

Grade: 9

Credits: 5

Course Title: **MATH LAB 1 / ALGEBRA I NJSLA**

Description: This course is intended for students who have not met minimum levels of competency on the NJSLA 8. The focus of this course will be to develop skills and knowledge in the five areas which are the focus of the NJSLA Algebra I test. The five areas are: 1) Number Sense, 2) Geometry, 3) Probability & Statistics, 4) Functions, 5) Algebra. Successful completion of this course will result in five elective credits and will not be considered a mathematical unit for graduation. This course is aligned to the Algebra I curriculum and is taken with Integrated Algebra I concurrently. Students are placed in this course due to NJSLA scores, grade in previous course and or teacher recommendation.

Prerequisite: Teacher recommendation or a placement test will be required for students to exit this math sequence at the end of the year.

Course #: 3573

Level: I

Grade: 10

Credits: 5

Course Title: **MATH LAB II / GEOMETRY NJSLA**

Description: This course is a continuation of the basic mathematical skills undertaken in a previous mathematics course. The focus of this course will be to develop skills and knowledge in five areas which are the focus of the NJSLA assessments. The five areas are: 1) Number Sense 2) Geometry 3) Probability, Statistics 4) Functions 5) Algebra. Successful completion of the course will result in five elective credits and will not be considered a mathematical unit for graduation. This course is aligned to the Geometry curriculum and is taken with Integrated Geometry concurrently. Students are placed in

this course due to NJSLA scores, previous grade in Algebra 1 and/or teacher recommendation. Teacher recommendation or a placement test will be required for students to exit this math sequence at the end of the year.

Course #: 3562
Level: I
Grade: 11-12
Credits: 5

Course Title: **MATH LAB III / ALGEBRA 2 NJSLA**

Description: This course is a continuation of the basic mathematical skills undertaken in a previous mathematics course. The focus of this course will be to develop skills and knowledge in five areas which are the focus of the NJSLA assessments. The five areas are: 1) Number Sense 2) Geometry 3) Probability, Statistics 4) Functions 5) Algebra. Successful completion of the course will result in five elective credits and will not be considered a mathematical unit for graduation. This course is aligned to the Algebra 2 curriculum and is taken with Integrated Algebra 2 concurrently. Students are placed in this course due to NJSLA scores, grade in previous course and or teacher recommendation. Teacher recommendation or a placement test will be required for students to exit this math sequence at the end of the year.

Course #: 3574
Level: I
Grade: 11-12
Credits: 5

Course Title: **MATH SENIOR PORTFOLIO**

Description: This course is a continuation of the basic mathematical skills undertaken in a previous mathematics course. The focus of this course will be to develop skills and knowledge in five areas which are the focus of the NJSLA assessments. The five areas are: 1) Number Sense 2) Geometry 3) Probability, Statistics 4) Functions 5) Algebra. Successful completion of the course will result in five elective credits and will not be considered a mathematical unit for graduation. This course is aligned to the Algebra 2 curriculum and will consist of the portfolio process. Students are placed in this course due to NJSLA scores and the need for alternate state assessment process. This course is for seniors and juniors with the possibility of graduation.

Course #: 3585
Level: II
Grade/s: 9-10-11-12
Credits: 5

Course Title: **ALGEBRA I - (College Preparatory)**

Description: The transition from the basic concepts of arithmetic to the abstractions of algebra is one of the prime objectives of this course. The course stresses the manipulation of algebraic symbols and expressions and working with integers to solve equations and inequalities. Other concepts include the study of number systems, the identification of relations, functions and the construction and interpretation of graphs.
Prerequisite: Teacher Recommendation.

Course # 3587

Level: III

Grade: 9

Credits: 5

Course Title: **ALGEBRA I - Honors**

Description: Algebra I Honors is a demanding Mathematics course for the accelerated student planning study at a college or university. This course focuses on the underlying structure of algebraic content as well as methods and applications. Successful completion requires that homework and studying be completed on a regular basis and that the student has a solid foundation in arithmetic skills.

Prerequisite: An 87 average and teacher recommendation. May be taken with Honors Geometry or Geometry CP with teacher recommendation.

Course #: 3590

Level: II

Grade/s: 9-10-11-12

Credits: 5

Course Title: **ALGEBRA II - Honors**

Description: This is an honors course designed for the student who has demonstrated a superior ability in mathematics. It introduces the solution of second-degree equations using the quadratic equation and graphing. It stresses the use and application of exponents and radicals. It introduces conic sections, including the equations and graphs for the circle, ellipse, parabola and hyperbola. Additional topics not normally covered in C.P. Algebra II include matrices and determinants, sequences and series. The course treats abstract mathematical concepts in an accelerated manner.

Prerequisite: Teacher Recommendation,

Honors Algebra I (passing score of 80% on the High School final exam, minimum of 85% final grade,

Honors Geometry (minimum of 85% final grade) or

Geometry CP (minimum final grade of 87%).

Course may be taken concurrently with Geometry (with teacher recommendation).

Course #: 3595

Level: II

Grade/s: 9-10-11-12

Credits: 5

Course Title: **ALGEBRA II - (College Preparatory)**

Description: Algebra II is designed for the academic student of average mathematical ability. The purpose of the course is to reinforce and refine all procedures learned in Algebra 1. It stresses solutions of more detailed equations and inequalities. It also exposes the student to various methods of problem solving. Graphing of linear equations is studied thoroughly and graphing of a quadratic equation is introduced. Basic concepts of logarithms are introduced. The real number system is developed and the complex system introduced.

Prerequisite: Algebra I Honors, Algebra I CP or Integrated Algebra I CP (minimum final grade of 87% AND teacher recommendation for Integrated Algebra I CP).

Algebra II and Geometry courses may be taken concurrently with teacher recommendation.

Course #: 3596
Level: II
Grade/s: 10-11-12
Credits: 5

Course Title: **INTEGRATED ALGEBRA II - (College Preparatory)**

Description: This course is designed as a continuation and extension of the first two integrated math courses. Students will learn many of the algebraic principles associated with Algebra II, some concepts of trigonometry, advanced statistical and probability methods, three-dimensional geometry, and other topics.

Prerequisite: Integrated Geometry or Geometry. Note: They may not be taken concurrently with Integrated Algebra I.

Course #: 3598
Level: II
Grade/s: 11-12
Credits: 5

Course Title: **INTEGRATED ALGEBRA III / with Trigonometry**

Description: This course integrates Algebra, Geometry, and Trigonometry. Student are exposed to various methods of problem solving and how to use Algebra and Trigonometry to model and solve authentic real-world problems. Students will continue the study of polynomial functions and their graphs to include transformations, graphing, and analysis. In addition, they will use and apply all formulas surrounding right and oblique triangles, trigonometric functions, equations, and graphs.

Prerequisites: Algebra I, II, Geometry (Integrated or CP)

Course #: 3707
Level: I
Grade/s: 10-11-12
Credits: 5

Course Title: **ALGEBRA II CONCEPTS - Modified**

Description: This course will review the basic operations of arithmetic, algebraic terminology, integers and absolute value. The course will also introduce solving linear equations, exponents, solving systems of equations and graphing. The curriculum will be appropriately modified by varying teaching techniques, strategies and materials to meet the educational needs of special education students as reflected in their Individual Education Program.

Prerequisite: Introduction to Algebra-Modified

Course #: 3690
Level: III
Grade/s: 9-10-11-12
Credits: 5

Course Title: **GEOMETRY - Honors**

Description: This course aims to teach concepts related to geometrical principles. Deductive and inductive reasoning, mathematical proof, area and volume, the coordinate plane, trigonometry and the reinforcement of the basic algebraic skills are emphasized.

Topics are treated in greater depth and at an accelerated pace than Geometry. This course is essential for those students who plan to take additional honors mathematics courses in the future.

Prerequisite: Teacher Recommendation,

Honors Algebra I (passing score of 80% on the High School final exam, minimum of 85% final grade), or

CP Algebra 1 (minimum final grade of 87%).

Algebra II may be taken concurrently with this course.

Course #: 3695

Level: II

Grade/s: 10-11-12 (9 with teacher recommendation)

Credits: 5

Course Title: **GEOMETRY - (College Preparatory)**

Description: The purpose of this course is to develop logical thinking and an appreciation for the practical applications of geometric concepts. This is achieved by relating geometric principles to daily situations and developing student skills in visualization, pictorial representation and the application of geometric ideas to describe and answer questions about natural phenomena. The course also emphasizes the integration of algebra and geometry to formulate and analyze problems. Students will develop deductive skills as applied to the construction of proofs.

Prerequisite: Algebra I Honors, Algebra I CP, or Integrated Algebra I CP (minimum final grade of 87% AND teacher recommendation for Integrated Algebra I CP).

Course #: 3698

Level: I

Grade/s: 10-11-12

Credits: 5

Course Title: **GEOMETRY CONCEPTS – Modified**

Description: The purpose of this course is to provide the student with basic geometric concepts and develop logical thinking and an appreciation for the application of geometry with modifications to meet the educational needs of special education students as reflected by their Individual Education Program.

Prerequisite: Intro to Algebra-Modified and Basic Algebra-Modified.

Course #: 3701

Level: I

Grade/s: 9-10-11-12

Credits: 2.5

Course Title: **MANAGING MONEY**

Description: This is a course designed for the student who has a solid mastery of basic computational skills and desires to become proficient in managing his personal finances. The content deals with the fundamental operations and principles that a student faces in his daily interaction with the business world

Course #: 3710
Level: I
Grade/s: 11-12
Credits: 5

Course Title: **APPLIED MATHEMATICS - Modified**

Description: This course is designed to review basic math concepts. Emphasis will be placed on how to write checks and maintain a checking account, how to calculate interest and finance charges and how to buy a car, etc. The curriculum will be appropriately modified by varying teaching techniques, strategies and materials to meet the educational needs of special education students as reflected in their Individual Education Program. Successful completion of this course will result in five elective credits and will not be considered a mathematical unit for graduation. Prerequisite: Int. Algebra 1 or Algebra 1

Course #: 3750
Level: III
Grade/s: 10-11-12
Credits: 5

Course Title: **PRECALCULUS/TRIGONOMETRY- Honors**

**Eligible for college credits from Camden County College- listed as Accelerated Pre-Calculus

Description: This course is designed for the student who has demonstrated a superior ability in mathematics. The course will include trigonometry and the continued study of advanced topics such as matrices, determinants, and sequences and series. In addition, the concepts of vectors, mathematical structures, Polar coordinates, (probability and statistics) will be studied. Throughout the course the relationship between algebra, geometry and functions will be stressed.

Prerequisite: Honors Algebra II or Algebra CP II with teacher recommendation

Course #: 3755
Level: II
Grade/s: 10-11-12
Credits: 5

Course Title: **TRIGONOMETRY / PRE-CALCULUS - (College Preparatory)**

Description: This course integrates algebra, geometry and trigonometry to help the student understand and better appreciate the role which each plays in mathematics. The topics studied include trigonometry, analytic geometry, functions and an introduction to calculus.

Prerequisite: Algebra II CP (It is suggested that students have a minimum grade of 75 in Algebra II CP and Geometry CP)

Course #: 3762
Level: II
Grade(s): 11-12
Credits: 5

Course Title: **CALCULUS - (College Preparatory)**

Description: This college-preparatory level course is particularly useful for students who plan to study mathematics, science, engineering, or any related fields at 2-year or 4-

year colleges. This course focuses on derivation, integration, differential equations, and applications in real-world scenarios. The material covered in this course is generally expected knowledge for first-year college students in mathematics courses.

Prerequisite: Trigonometry/Pre-Calculus or Honors Trigonometry (it is recommended that students have an overall grade of 75 or higher)

Course #: 3765

Level: III

Grade/s: 11-12

Credits: 5

Course Title: **CALCULUS - Honors**

Description: This course is important to any student going to college, especially if the student is majoring in Mathematics, Science, Engineering, Computer Science or Business. Many colleges today expect the student to have some knowledge of calculus when they enter. This course covers the derivative, differentiation, integration, differential equations, and their application.

Prerequisite: Trig/Pre-Calculus or Honors Trig. with Honors prerequisite

Course #: 3770

Level: IV

Grade/s: 11-12

Credits: 5

Course Title: **AP CALCULUS/AB - (Advanced Placement)**

**Eligible for college credits from Camden County College- listed as Calculus I

**Eligible for college credits from Rowan College at Burlington County- listed as Calculus I & Analytic Geometry

Description: This Advanced Placement Mathematics Course follows the syllabus provided by the College Board. The AP examination is required and tests the student's knowledge of differential and integral calculus typically included in the Calculus I College Course. The use of graphing calculators is an integral part of the course. Students are expected to take the advanced placement examination.

Prerequisite: Honors Trig., Trig. – Pre-Calculus or Honors Calculus. A grade of 87 or better in the previous Honors Course or a 92 or better in the previous College Preparatory course.

Course #: 3771

Level: IV

Grade: 12

Credits: 5

Course Title: **AP CALCULUS/BC – (Advanced Placement)**

**Eligible for college credits from Rowan College at Burlington County- listed as Calculus I & Analytic Geometry; Calculus II & Analytic Geometry

Description: This Advanced Placement Mathematics Course follows the syllabus provided by the College Board. AP Calculus BC extends the content learned in AB to different types of equations (polar, parametric, vector-valued) and new topics (such as Euler's method, integration by parts, partial fraction decomposition, and improper integrals), and introduces the topic of sequences and series. The AP course covers topics

in differential and integral calculus, including concepts and skills of limits, derivatives, definite integrals, the Fundamental Theorem of Calculus, and series. The course teaches students to approach calculus concepts and problems when they are represented graphically, numerically, analytically, and verbally, and to make connections amongst these representations. Students learn how to use technology to help solve problems, experiment, interpret results, and support conclusions. The use of graphing calculators is an integral part of the course. Students are expected to take the advanced placement examination.

Prerequisite: AP CALCULUS/AB. A grade of 87 or better in AP CALCULUS/AB course.

Course #: 3772
Level: IV
Grade/s: 11-12
Credits: 5

Course Title: **AP STATISTICS - (Advanced Placement)**

**Eligible for college credits from Camden County College- listed as Intro to Statistics

**Eligible for college credits from Rowan College at Burlington County- listed as Intro to Statistics

Description: This Mathematics Advanced Placement course follows the syllabus provided by the College Board. The AP examination is required and tests the student's knowledge of statistics and statistic analysis. The topics include: exploring data, planning a study, anticipating (using probability and simulation) patterns, and statistical inference. The use of a graphing calculator with statistical capabilities is required. Students are expected to take the advanced placement examination.

Prerequisite: Honors Trig., Trig.-Pre-Calculus or Honors Calculus. A grade of 87 or better in the previous Honors Course or a 92 or better in the previous College Preparatory course.

Course #: 2495
Level: II
Grade/s: 10-11
Credits: 2.5 - First Semester Course

Course Title: **SAT PREP- (College Preparatory)**

Description: SAT PREP is designed to help students maximize their scores in the math and verbal sections of the SAT through daily application and practice with the techniques and concepts assessed on the exam.

Prerequisite: Geometry or Integrated Geometry.

MUSIC COURSE SEQUENCES

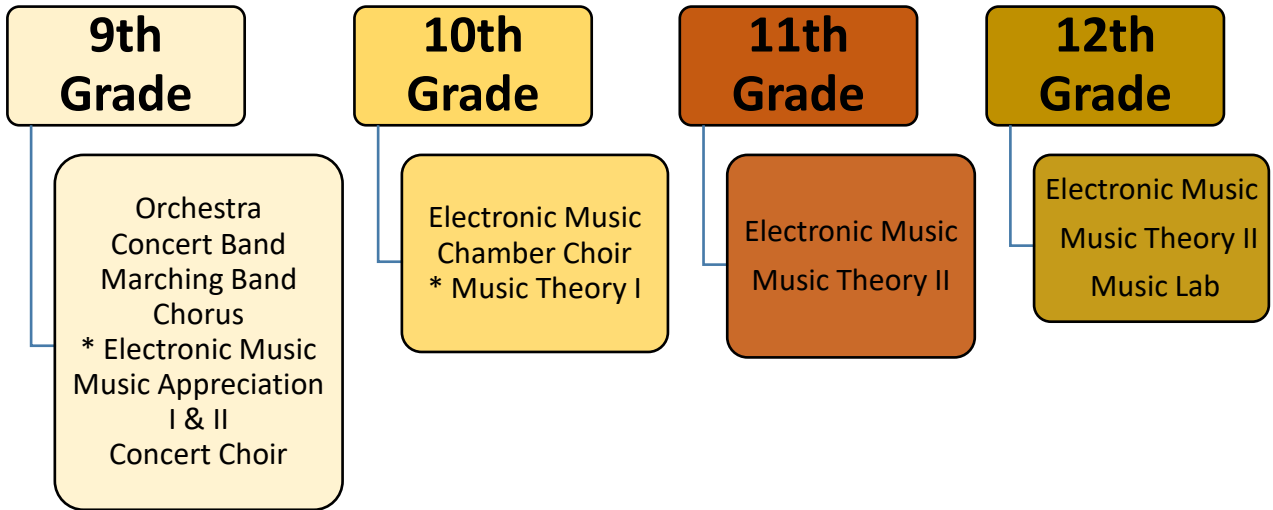

All Music courses meet graduation requirements for Visual/Performing Arts.
 Courses with (*) meet graduation requirements for 21st Century Life and Careers or Career-Technical Education.

Course #: 5471
 Level: I
 Grade/s: 9-10-11-12
 Credits: 2.5
 Course Title: **MARCHING BAND**
 Length: 9 weeks
 Description: This after-school activity is offered for credit during the 1st quarter. Marching Band fulfills 2.5 credits, and is one of the school's most prominent organizations.
 Prerequisite: Prior band instrumental experience, teacher approval
 Co-requisite: Concert Band

Course #: 5430-5433 / 5467 / 5470 / 5434*
 Level: II / III
 Grade/s: 9-10-11-12
 Credits: 5
 Course Title: **BAND I, II, III, IV / Honors**
 Description: The band will provide ensemble experience for the instrumental music student who is not interested in participating in marching band. The development of techniques, interpretation, intonation and general musicianship will be emphasized. Students taking this course should realize that the course requires attendance at all public performances and demands that the students be available for after school rehearsals. Students may take Band as an honors level course after an audition.
 *Note: This course may be taken for 2.5 credits as Band/Lunch (Course #5434).

Prerequisite: Student should have the ability to read music, play a band instrument and be recommended by a music teacher.

Course #: 5445-5448 / 5482-5485

Level: II / III

Grade/s: 9-10-11-12

Credits: 5

Course Title: **JAZZ BAND I, II, III, IV / Honors**

Description: Jazz Band provides ensemble experiences in the popular jazz music field. Various styles of music will be discussed and performed. Emphasis will be placed on creating and performing popular styles. Students taking this course should realize that the course requires attendance at all public performances. Jazz Band/Lunch (Course # 5487) 2.5 credits

Prerequisite: Admission to Jazz Band is by audition only. Students must be able to read music and play a jazz band instrument.

Course #: 5435-5438 / 5472 / 5475 / 5460*

Level: II / III

Grade/s: 9-10-11-12

Credits: 5

Course Title: **ORCHESTRA I, II, III, IV/ Honors**

Description: Students learn techniques of playing a stringed instrument while studying works of various composers and musical styles. All students participate in the string orchestra; advanced players may audition for the Chamber Orchestra. Students are **REQUIRED** to attend ALL rehearsals and performances. Students may take Orchestras as an honors level course if they meet the honors prerequisite.

*Note: Students may enroll in Orchestra with an Orchestra/Lunch option for 2.5 credits (Course #5460). Prerequisite: Ability to play the violin, viola, cello or string bass

Course #: 549101-549104 / 549201-549204

Level: II / III

Grade/s: 9-10-11-12

Credits: 5

Course Title: **CONCERT BAND / Honors**

Description: This is an elective music course designed for the developing of high school musician to participate in a performing instrumental ensemble. Students who are on this ensemble will develop their musical talents both as an individual and as a group participant in the concert band. The course includes a daily full ensemble class, supplemented by a weekly scheduled small group lesson during the school day. This course is structured to develop the following: instrumental technique, ensemble technique, music literacy and history, critical listening and evaluation skills, etiquette as a performer, musicianship, and understanding of potential careers in music. Required responsibilities outside the classroom include attendance and participation in all scheduled rehearsals/performances.

Prerequisite: Students must have the ability to play a Concert Band instrument as determined by an audition or recommendation.

Course #: 5455
Level: II
Grade/s: 10-11-12
Credits: 2.5

Course Title: **ELECTRONIC MUSIC I**

Description: Electronic Music I provides students with practical knowledge related to the basics of electronic music production. Students learn how to compose music using MIDI sequencing technology and sample editing. Students also learn traditional recording techniques in this class. This course focuses on popular music genres including hip-hop, ambient, house, techno, trip-hop and dub-step. Students will acquire both theoretical knowledge and practical “hands on” experience in the production of music. The lectures cover the theory and history of digitizing music, archiving to media, sample editing, digital signal processing, synthesis, a sampling, MIDI, sequencing and mixing. Labs provide “hands on” experience in composition and include explanations on how to create specific musical genres and sounds.

Prerequisite: None; however, the ability to read music is helpful, but not necessary.

Course #: 5459
Level: II
Grade/s: 10-11-12
Credits: 2.5 Semester Course

Course Title: **ELECTRONIC MUSIC II**

Description: This course takes a hands-on approach to learning and is about creating, recording, mixing, and mastering musical productions. Students will be introduced to the art and business of creating and selling recorded music of varied genres and styles. The tools and techniques of recording with control surfaces will be explored as students begin to use the recording studio as their creative laboratory. Electronic Music II will provide the students the opportunity to study the “artist,” how musical talent is identified and cultivated, how material is selected and arranged, how a complete album is constructed in the studio, and how the audience and artist have historically influenced each other. The course culminates with a ‘Capstone Project’ in which students will develop a full creative plan to launch themselves as entrepreneurs. This project includes launching a record label, creating a production company, developing new media, and starting an innovative music venue.

Course #: 5440 / 5443 / 5444*
Level: I
Grade/s: 9-10-11-12
Credits: 5

Course Title: **CHORUS**

Description: The course is designed for the developing high school singer who wishes to participate in a performing vocal ensemble. Any student with the desire to sing and learn to read music is encouraged to participate. Public performances are a required part of the course. Students in the chorus will develop their musical talents and abilities. *Note: Students may enroll in chorus with a Chorus/Lunch option for 2.5 credits (Course #5444).

Course #: 544010/544110/544210/544310

Level: I

Grade/s: 9-10-11-12

Credits: 2.5

Course Title: **CHORUS (Semester)**

Description: The course is designed for the developing high school singer who wishes to participate in a performing vocal ensemble. Any student with the desire to sing and learn to read music is encouraged to participate. Public performances are a required part of the course. Students in the chorus will develop their musical talents and abilities.

Course #: 546201 – 546204 / 546301 - 546304

Level: I / II / III

Grade/s: 9-10-11-12

Credits: 5

Course Title: **CONCERT CHOIR**

Description: This course is designed for the advanced high school singer with an outstanding voice and the ability to read and interpret written music. Rotating lessons are part of the honors course in order to advance individual technique. Public performances are a required part of the course. Honor students will be required to audition for South Jersey and All State Chorus. Students may enroll in concert choir with a Concert Choir/Lunch option for 2.5 credits (Course #5464).

Course #: 546205/ 546206/546207/546208

Level: I

Grade/s: 9-10-11-12

Credits: 2.5

Course Title: **CONCERT CHOIR (Semester)**

Description: This course is designed for the advanced high school singer with an outstanding voice and the ability to read and interpret written music. Rotating lessons are part of the honors course in order to advance individual technique. Public performances are a required part of the course. Honor students will be required to audition for South Jersey and All State Chorus.

Course #: 546501 / 546502 / 546503

Level: II / III / IV

Grade/s: 10-11-12

Credits: 5

Course Title: **CHAMBER CHOIR / Honors**

Description: Chamber Choir is an auditioned vocal ensemble designed to give the finest and most ambitious singers in the school the opportunity to advance their vocal technique and music theory knowledge to collegiate levels. The Chamber Choir will strive to represent the school community at the highest level. Public performances are a required part of the course. Members of the Chamber Choir have a private vocal lesson approximately every six weeks. Students are required to audition for South Jersey Chorus and All State Chorus, and seniors are required to perform in the Senior Honors Recital.
Prerequisite: By audition only, with at least one year of Concert Choir or Chorus.

Course #: 5450
Level: II
Grade/s: 10-11-12
Credits: 5

Course Title: **MUSIC THEORY I**

Description: This course teaching the foundation of music, including rhythm, harmony and melody applications. This course is designed to assist the student in understanding how music is created, written and sung. Students will be able to create music as an outgrowth of participation in this course.

Prerequisite: Students should have the ability to read music, sing or play an instrument.

Course #: 5456 / 5457
Level: II / III
Grade/s: 11-12
Credits: 5

Course Title: **MUSIC THEORY II / MUSIC THEORY II -Honors**

Description: This course will begin a study of the fundamentals of music and progress through a study of harmonic structure from 1600 to today. Intense analysis of the individual structural elements of rhythm, harmony, melody and form, along with ear training exercises will comprise much of the content.

Prerequisite: Ability to read music. A grade of 87 or better in the previous College Preparatory course or a grade of 83 or better in the previous Honors course.

Course #: 5458
Level: IV
Grade/s: 11-12
Credits: 5

Course Title: **AP MUSIC THEORY - (Advanced Placement)**

Description: This music theory advanced placement course follows the syllabus followed by the College Board. This course is equivalent to a full-year introductory college course in music theory. Students are expected to take the advanced placement examination, which is comprised of a 2 ¾ hour written portion and an 8-minute sight-singing portion. The examination tests the students' aural and visual understanding of musical structure and compositional procedures. It assumes fluency in reading notation, developing listening skill and the ability to integrate these skills in sight singing. Visual and aural understanding are tested in relation to musical elements and compositional procedures. Students are required to take melodic and harmonic dictation and to do part writing and composition exercises.

Prerequisite: Music Theory I and II. A grade of 87 or better in the previous Honors Course or a 92 or better in the previous College Preparatory course.

Course #: 5452

Level: I

Grade/s: 9-10-11-12

Credits: 2.5 – Semester Course

Course Title: **MUSIC APPRECIATION I**

Description: This course is a survey of music from its origins to the 19th Century. This course requires listening to music in class with subsequent discussion and analysis.

Course #: 5453

Level: I

Grade/s: 9-10-11-12

Credits: 2.5 – Semester Course

Course Title: **MUSIC APPRECIATION II**

Description: This course is a survey of music from the 19th Century to Contemporary Era. This course requires listening to music in class with subsequent discussion and analysis.

Course #: 5520

Level: I

Grade/s: 11-12

Credits: 3

Course Title: **MUSIC/LAB**

Description: This course will meet three days per week for students currently enrolled in an AP Lab Science. Music Lab will be a pass/fail grade and will not be calculated into the GPA.

SCIENCE SUGGESTED COURSE SEQUENCES

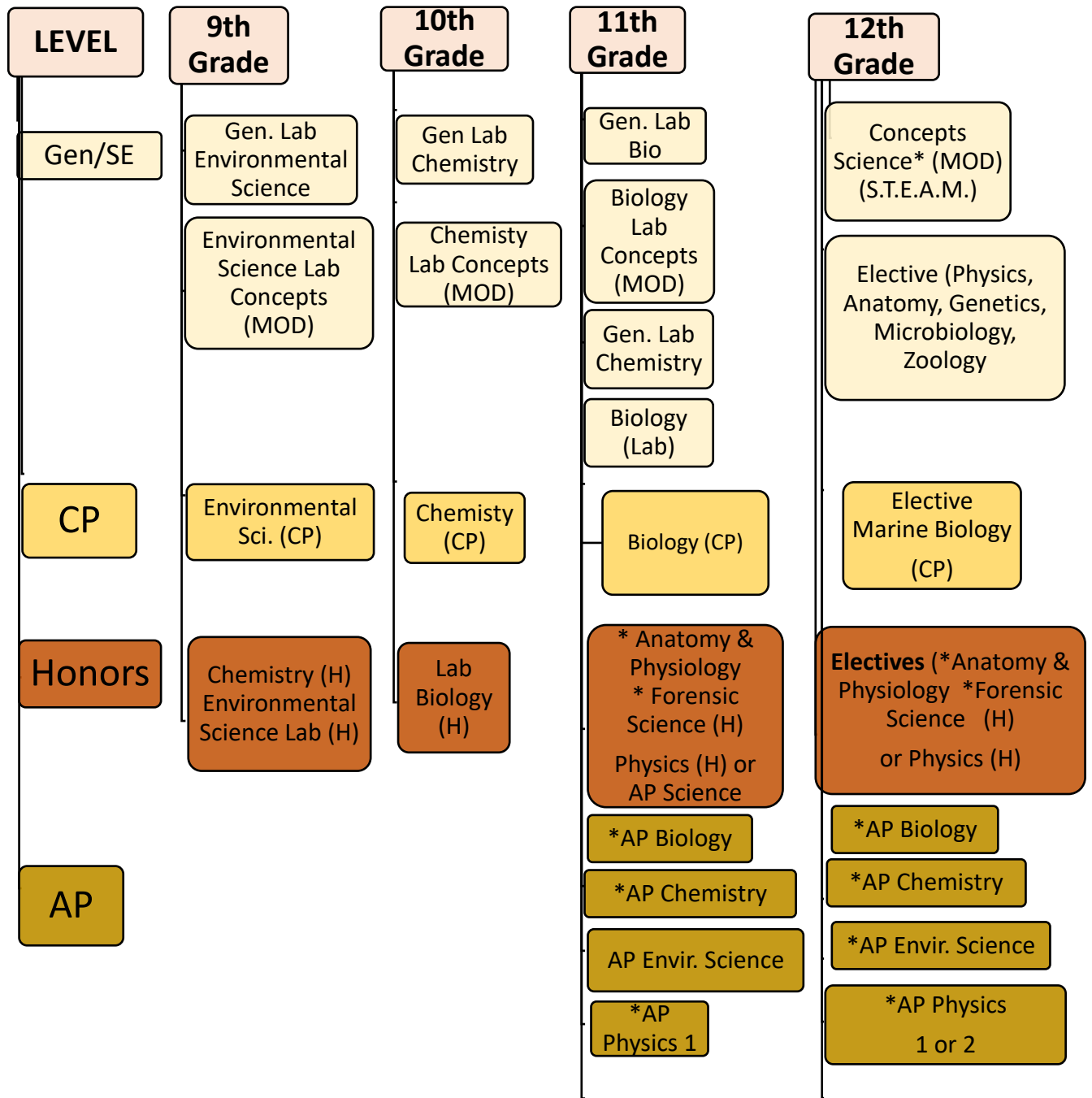

These courses (*) meet graduation requirements for 21st Century Life and Careers or Career-Technical Education.

INTRODUCTION: Three (3) years of science including laboratory biology; chemistry, physics or environmental science; and a third inquiry-based lab or technical science are

required for graduation. Students who anticipate taking college level work or pursuing a science-related career (e.g. technical, health) should elect laboratory biology and chemistry and physics. New Jersey State four-year colleges and universities require at least two (2) years of laboratory science; generally, laboratory biology and chemistry. Recent developments in science and technology make this area a "must" for a successful career in tomorrow's society.

Course #: 3132

Level: I

Grade/s: 11-12

Credits: 5

Course Title: **GENERAL LAB BIOLOGY**

Description: This course examines the biological concepts of the cell as the basic unit of structure and function of all organisms. Focus will continue on the understanding of DNA and heredity towards the end of the first semester. The second half of the year will concentrate on Evolution, Taxonomy, Kingdom of Life and an Introduction to Body Systems. Visual demonstrations, laboratory investigations, and multimedia demonstrations may be used to supplement this course.

Prerequisite: Two years of science.

Course #: 3032

Level: I

Grade: 9

Credits: 5

Course Title: **GENERAL LAB ENVIRONMENTAL SCIENCE**

Description: This course is designed to present to students experiences that will assist them in making sound environmental decisions as individuals and members of society. It is expected to raise consciousness regarding the preservation of the environment and what can be done at the local, state and national levels to attain this objective. Topics covered are energy/alternative energy sources, recent developments in energy production, ecology, ecosystems, and conservation of resources, populations, and human impact on the environments.

Course #: 3037

Level: III

Grade/s: 11-12

Credits: 5

Course Title: **BIOLOGY LAB CONCEPTS- Modified**

Description: This course will introduce students to life science focusing specifically on biology. Students will explore the world of living organisms, beginning with the simplest known living things and ending with the most complex organism of all, the human being. Throughout the year students will be given the opportunity to engage in hands-on activities that will include laboratory experiences and small group projects. The final marking period will be devoted to the study of the systems of the human body.

The curriculum will be appropriately modified by varying teaching techniques, strategies and materials to meet the educational needs of special education students as reflected in their Individual Educational Plan.

Course #: 3034

Level: I

Grade: 9

Credits: 5

Course Title: **ENVIRONMENTAL LAB CONCEPTS - Modified**

Description: This course is designed to provide students with experiences that will assist them in making sound environmental decisions as individuals and members of society. Throughout the year, students will explore the delicate balance of nature. Students will engage in hands-on experiences including laboratory experiences and small group projects. The curriculum will be appropriately modified by varying teaching techniques, strategies and materials to meet the educational needs of special education students as reflected in their Individual Educational Plan.

Course #: 3075

Level: III

Grade/s: 10-11-12

Credits: 5

Course Title: **LAB BIOLOGY - Honors**

Description: This course covers essentially the same materials as Lab Biology, but in greater depth and at an accelerated pace. Emphasis is placed on experimentation, analysis and evaluation of data. Students are expected to work well independently. Laboratory Biology is required by many colleges for admission purposes. It is strongly recommended that students, who plan to continue their education beyond high school, particularly in academic/career areas involving science, take this course.

A grade of 87 or better in previous College Preparatory course or a grade of 83 or better in the previous Honors course.

Course #: 3130

Level: II

Grade/s: 11-12

Credits: 5

Course Title: **LAB BIOLOGY - (College Preparatory)**

Description: This college preparatory course will develop the basic biological concepts with emphasis on the cell as the basic unit of structure and function of all organisms. Topics will include cell biology, biochemistry, DNA and genetics. During the second half of the year emphasis is on understanding the organization of life through study of Evolution and the Classification System with study of the Six Kingdoms of Life. The year ends with a focus on viruses and bacteria, principles of Ecology and biological populations. Visual demonstrations, laboratory investigations, multimedia demonstrations, and controlled experiments will be used to supplement this course.

Prerequisite: Chemistry CP

Course #: 3220
Level: II
Grade/s: 11-12
Credits: 5

Course Title: **ANATOMY AND PHYSIOLOGY - (College Preparatory)**

Description: This course is an in-depth study of selected areas of human biology. Areas of study will include microbiology and in depth study of the human body and its functions. This course is helpful to those students anticipating a career in biotechnology and medical science at a two or four-year College.

Prerequisite: A 'C' or Better in Chemistry Lab CP and Lab Biology CP.

Course #: 3221
Level: III
Grade/s: 11-12
Credits: 5

Course Title: **ANATOMY AND PHYSIOLOGY – Honors**

**Eligible for college credits from Camden County College- listed as Human Biology

Description: This course is a study of selected areas of human body. Areas of focus will include microbiology and an in-depth study of the human body and its functions. This course is helpful to those students anticipating a career in biotechnology and medical science at a two or four-year College.

Prerequisite: A grade of 87 or better in Lab Biology CP and Chemistry Lab CP or a grade of 83 or better in Lab Biology Honors and Chemistry Lab Honors course.

Course #: 3225
Level: IV
Grade/s: 11-12
Credits: 6

Course Title: **AP BIOLOGY - (Advanced Placement)**

**Eligible for college credits from Camden County College- listed as Biology I-Science

**Eligible for college credits from Rowan College at Burlington County- listed as General Biology I & II

Description: This 11th or 12th grade course follows the syllabus that has been approved by The College Board. Advanced Placement Biology provides an in-depth classroom and laboratory study of Biology with an emphasis on molecular Biology. Topics in Biochemistry, Cell Biology, Energy Transformations, Molecular Genetics, and Heredity will be examined. The Taxonomy and the structure of living kingdoms are also examined. Laboratory exercises are those that are approved by The College Board and serve to reinforce the facts, principles, and concepts presented in the classroom. Laboratory encourages skills in observation, record keeping, data interpretation, and operation of technical equipment. This course is designed for students who have demonstrated strong academic achievement in a prior Honors or College Prep Biology course who plan to continue study in Biology or a related field at the college level. Completion of summer assignments prior to entering the course in September is mandatory. Students are encouraged to take the Advanced Placement examination.

Prerequisite: A grade of 87 or better in Honors Chemistry and Honors Biology OR a grade of 92 or better in CP Chemistry and CP Biology

Course #: 3175

Level: III

Grade/s: 9-10

Credits: 5

Course Title: **CHEMISTRY / LAB - Honors**

Description: This course covers the same content with a more in depth study of the topics as Chemistry Lab, but at an accelerated pace. More extensive lab work is required. Students must be able to work independently.

Prerequisite: Completion of Algebra I and a recommendation. 10th grade: Algebra 1 and minimum grade of 87 in Environmental Science Lab. CP.

Course #: 3180

Level: II

Grade: 10

Credits: 5

Course Title: **CHEMISTRY / LAB - (College Preparatory)**

Description: Chemistry/Lab is course of study designed to prepare the student for the chemistry that may be encountered in college, nursing school, or any related technical field. Chemistry is the study of matter its structure, composition and the changes it undergoes. Major topics covered are: Atomic Theory, the Periodic Table, chemical reactions, acid-base theory, chemical bonding, kinetic molecular theory and solutions. Laboratory experiments are conducted to support topics studied. This course requires students to apply mathematics to real problem-solving situations.

Prerequisite: Algebra I or Integrated Algebra I and Environmental Science

Course #: 3270

Level: II

Grade: 9

Credits: 5

Course Title: **ENVIRONMENTAL SCIENCE CP**

Description: This course will investigate the interconnectedness of humans and their environment. Students will explore different aspects of biology and how living things are impacted by the world around them. Students will gain a better understanding of our role in the delicate balancing acts that take place on earth and be better prepared to make sensible environmental decisions. This course will study ecology, populations, water, air, land, minerals, energy resources, the earth's health, and the earth's future.

Course #: 3036

Level: III

Grade: 9

Credits: 5

Course Title: **ENVIRONMENTAL SCIENCE - Honors**

Description: This course will investigate the interconnectedness of humans and their environment at an advanced level. Students will explore different aspects of biology and how living things are impacted by the world around them. Students will gain a better understanding of our role in the delicate balancing acts that take place on earth and be better prepared to make sensible environmental decisions. This course will introduce

STEM concepts as they relate to environmental science. This course will study ecology, populations, water, air, land, minerals, energy resources, the earth's health, STEM concepts and the earth's future. This course will be offered to freshmen (9th Grade) students enrolled in the STEAM Science Academy. Students may enroll in Honors Chemistry concurrently with this course.

Course #: 3202

Level: IV

Grade/s: 11-12

Credits: 6

Course Title: **AP CHEMISTRY - (Advanced Placement)**

**Eligible for college credits from Camden County College- listed as Chemistry I- Science

**Eligible for college credits from Rowan College at Burlington County- listed as General Chemistry I & Lab; General Chemistry II & Lab

Description: This 11th or 12th grade course follows the syllabus provided by the College Board. The advanced placement chemistry course is designed to be the equivalent of a general chemistry course usually taken during the first year of college. This course builds on topics that were introduced in honors chemistry. New topics will also be introduced. This course will require students to think clearly and to express their ideas both orally and in writing, with clarity and logic. There is an emphasis on the quantitative aspects of chemistry. A strong algebraic background is needed. Completion of summer assignments prior to entering this course in September is mandatory. Students are expected to take the advanced placement examination.

Prerequisite: A grade of 85 or better in the previous Honors Course or a 92 or better in the previous College Preparatory course.

Course #: 3231

Level: IV

Grade/s: 11-12

Credits: 6

Course Title: **AP ENVIRONMENTAL SCIENCE - (Advanced Placement)**

**Eligible for college credits from Camden County College- listed as Living in the Environment

Description: Advanced Placement Environmental Science is a systematic study of our environment and our proper place in it. It is highly interdisciplinary, integrating natural sciences, political sciences, social sciences, and humanities in a broad, holistic study of the world around us. It is expected to raise consciousness regarding the conservation of the environment and what can be done at the local, state, and national levels to attain this objective. Topics covered are energy use, alternative energy sources, recent development in energy production, ecology, ecosystems, conservation of resources, human population growth, environmental health and toxicology, food and agriculture, land use, indigenous peoples land rights, pest control, water management, pollution, urbanization and sustainable cities, environmental policy, law, and planning, and environmental protection as a human right. The Advanced Placement Environmental Science course is designed to be the equivalent of a college introductory Environmental Science course with a laboratory. Many Colleges and Universities nationally accept results of a good score on

the AP Exam as evidence of competency in a collegiate level introductory Environmental Science Course. Students entering this course are expected to have a superior understanding of science prior to enrollment.

Prerequisite: A grade of 85 or better in the previous Honors Course or a 92 or better in the previous College Preparatory course.

Course #: 3260

Level: I

Grade/s: 11-12

Credits: 5

Course Title: **CONCEPTS OF SCIENCE - Modified (S.T.E.A.M)**

Description: This course is designed to present to students, experiences that will provide information in four broad content areas. The areas covered are Environmental science, Research and Current Events, Chemistry and Forensic. Each of the four content areas will be taught for one marking period. The curriculum will be appropriately modified by varying teaching techniques, strategies and materials to meet the needs of special education students as reflected in their Individualized Education Program.

Prerequisite: Successfully Passing Biology and Chemistry Lab with a 'C' or better.

Course #: 3215

Level: III

Grade/s: 11-12

Credits: 5

Course Title: **PHYSICS / LAB - Honors**

Description: This course covers the five major areas of this science: mechanics; electricity and magnetism; wave motion; sound and light. Two major areas of mechanics, electricity, and magnetism are singled out for in-depth treatment. Students are expected to develop competence in laboratory techniques and to improve their analytical thinking and problem-solving skills. A strong mathematics background is essential.

Prerequisite: Algebra I and a grade of 87 or better in the previous College Preparatory course or a grade of 83 or better in the previous Honors course. Recommended

Prerequisite: Geometry

Course #: 3206

Level: IV

Grade/s: 11-12

Credits: 6

Course Title: **AP PHYSICS I**

**Eligible for college credits from Camden County College- listed as Physics I

**Eligible for college credits from Rowan College at Burlington County- listed as Principles of Physics I & Lab

Description: AP Physics 1 is the equivalent to a first-semester college course in algebra-based physics. The course covers Newtonian mechanics (including rotational dynamics and angular momentum); work, energy, and power; and mechanical waves and sound. It will also introduce electric circuits. Students will build their understanding and critical thinking skills through inquiry-based, laboratory investigations that explore these physics concepts. Eligible for Camden County College Credit

Prerequisite: Geometry (may not be taken concurrently)
Recommended Prerequisite: College Prep or Honors Physics

Course #: 3208
Level: IV
Grade/s: 11-12
Credits: 6

Course Title: **AP PHYSICS II**

**Eligible for college credits from Camden County College- listed as Physics II

**Eligible for college credits from Rowan College at Burlington County- listed as Principles of Physics II & Lab

Description: This course is the equivalent to a second-semester college course in algebra-based physics. The course covers fluid mechanics; thermodynamics; electricity and magnetism; optics; and atomic and nuclear physics. Students will build their understanding and critical thinking skills through inquiry-based, laboratory investigations that explore these physics concepts. Eligible for Camden County College Credit

Prerequisite: AP Physics 1 (may be taken concurrently) and Geometry (may not be taken concurrently)

Recommended Prerequisite: College Prep or Honors Physics

Course #: 3247
Level: II
Grade/s: 11-12
Credits: 2.5 Semester Course

Course Title: **ZOOLOGY - (College Preparatory)**

Description: This course will provide a more in-depth study of the characteristics, physiology, and classification of animals than would be found in a typical biology course. Emphasis will be placed on native southern New Jersey region animal life.

Prerequisite: A Passing Grade in CP Chemistry and CP Biology

Course #: 3253
Level: II
Grade/s: 11-12
Credits: 2.5 (Semester Course)

Course Title: **MARINE BIOLOGY - (College Preparatory)**

Description: This course will provide the student with an in-depth study of characteristics, physiology, and classification of animal and plant life found in various bodies of water, as well as the geological aspects of the world's oceans. This lab-based course will examine multiple forms of aquatic animals, plants and geological structures throughout the year.

Prerequisite: A Passing Grade in CP Chemistry and CP Biology

Course #: 3252
Level: III
Grade/s: 11-12
Credits: 5

Course Title: **FORENSIC SCIENCE – Honors**

**Eligible for college credits from Camden County College- listed as Intro to Forensic Science

Description: This course introduces students to the application of science to criminal investigation and the role of science in the criminal justice system. A basic understanding of genetics, DNA, heredity, mutations, and gene mapping will be taught. Up to date technologies, such as DNA profiling, chemistry related lab techniques and crime scene investigation will be included. Actual case histories will be discussed and students will learn how Forensic Science has impacted the “crimes of the century.”

Prerequisite: minimum grade of 87 in Lab Biology CP and Chemistry Lab CP or minimum grade of 83 in Lab Biology Honors and Chemistry Lab Honors

Course #: 3217
Level: II
Grade/s: 11-12
Credits: 5

Course Title: **PHYSICS/LAB**

Description: This course covers the five major areas of physics: mechanics, electricity and magnetism, wave motion, and sound and light. The two major areas of mechanics and electricity and magnetism will be studied in depth. Students are expected to gain competence in laboratory techniques and to improve their analytical thinking and problem-solving skills. A strong background in mathematics is essential.

Prerequisite: Algebra I or Integrated Algebra I, and Biology Lab.

Recommended Prerequisite: Geometry

Course #: 3185
Level: I
Grade: 11
Credits: 5

Course Title: **GENERAL LAB CHEMISTRY**

Description: The study of matter and the changes it undergoes will be explored. Lab demonstrations, student activities, and multimedia presentations may be used to supplement this course.

Course #: 3160
Level: I
Grade: 10
Credits: 5

Course Title: **CHEMISTRY LAB CONCEPTS - (Modified)**

Description: This course will introduce students to general concepts of chemistry. Students will develop a competency with lab techniques by participating in a variety of hands-on experiences and/or small group projects. This course will provide a general

understanding of chemistry topics and their relationship to everyday life. The curriculum will be appropriately modified by varying teaching techniques, strategies and materials to meet the educational needs of special education students.

Prerequisite: Environmental Science

Course #: 3241

Level: II

Grade/s: 11-12

Credits: 2.5 (Semester Course)

Course Title: **CP LABORATORY MICROBIOLOGY**

Description: This lab-based course examines the classification of microorganisms, microbe structure and function, microbial growth, metabolic diversity, microbial diversity and ecology, and microbe-host interactions. Applied microbiology will be addressed through the study of food preparation and safety, the use of microorganisms in industry, agriculture, biotechnology, and the environment. Disease and epidemiology will also be covered.

Prerequisites: A Passing Grade in CP Chemistry and CP Biology

Course #: 3242

Level: II

Grade/s: 11-12

Credits: 2.5 (Semester Course)

Course Title: **CP LABORATORY GENETICS**

Description: An in-depth study of genetics and heredity are examined in this semester course. The course reviews topics in Mendelian genetics and introduces students to a variety of other topics including genetic engineering, patterns of inheritance, sex-related genetics, and blood genetics. Diseases and disorders associated with inheritance will also be discussed.

Prerequisite: A Passing Grade in CP Chemistry and CP Biology

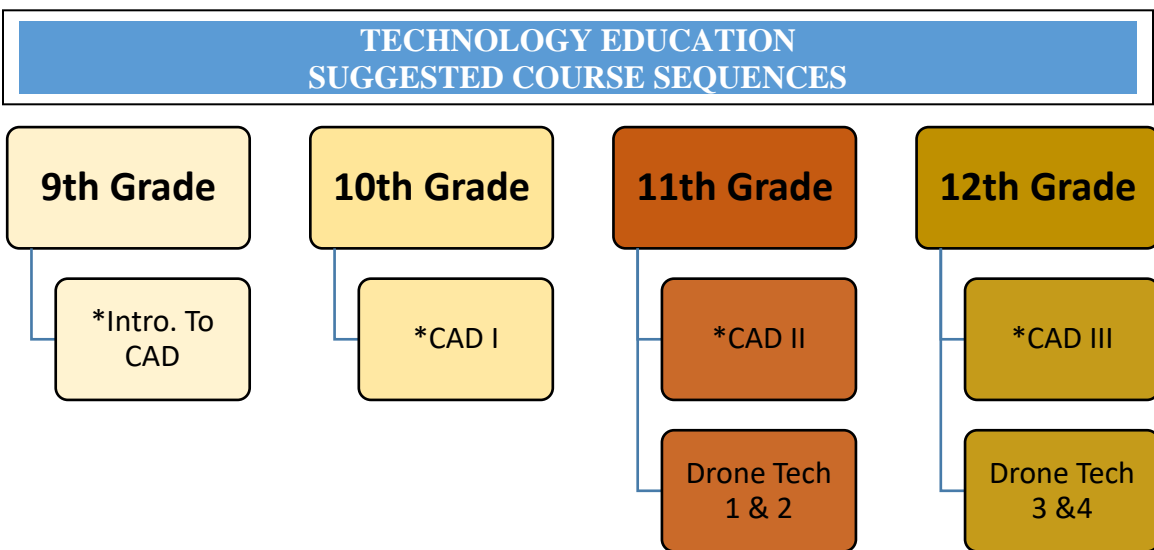

These courses (*) meet graduation requirements for 21st Century Life and Careers or Career-Technical Education. Courses with (*) also meet Visual/Performing Arts requirements.

Course #: 5204
Level: II
Grade/s: 9-10-11-12
Credits: 5

Course Title: **INTRODUCTION TO COMPUTER AIDED DRAFTING**

Description: This program is intended for 9th, 10th, 11th and 12th grade students who wish to further their education in a technical field. This includes an option for two and four-year college-bound students who intend to pursue degrees in architecture or engineering. The program uses AutoDesk's AutoCAD 2006. The assigned problems will require students to make use of the commands and functions available. Simple design projects will be introduced simulating "real world" applications such as residential architectural applications.

Prerequisite: Algebra I or Integrated Algebra I or concurrent enrollment in either of these courses is required. Geometry is strongly recommended

Course #: 5205
Level: II
Grade/s: 10-11-12
Credits: 5

Course Title: **COMPUTER AIDED DRAFTING I**

Description: This is intended for 10th, 11th and 12th grade students who wish to further their education in a technical field. This could include college-bound students who intend to pursue degrees in engineering or students who may wish to pursue a two-year program offered at a community college. The program will include drafting techniques used in AUTO CAD and other programs. The assigned problems will require the students to make use of the commands and functions available on these programs. Simple design projects will be introduced and progress to more complex drawings.

Prerequisite: Introduction to Computer Aided Drawing.

Course #: 5215
Level: II
Grade/s: 11-12
Credits: 5

Course Title: **COMPUTER AIDED DRAFTING II**

Description: Computer Aided Drafting II is an extension of Computer Aided Drafting I. Work will include more difficult drawing problems including orthographic and isometric representation including section and auxiliary views.

Prerequisite: Computer Aided Drafting I

Course #: 5220
Level: II
Grade/s: 11-12
Credits: 5

Course Title: **COMPUTER AIDED DRAFTING III - (Independent Study)**

Description: This course is specifically designed for the student who has excelled in Introduction to CAD, CAD I and CAD II. Students will design and develop two long-term assignments. These full scope community style projects include both residential and commercial elements. They cover most aspects of architectural drafting and design from concept to completion. They are inherently cross-curricular in nature in that the CAD projects support and amplify assignments in other academic areas. Students will be responsible for presenting their work to the CAD I and CAD II students as a way of simulating “real world” client interactions. These projects could also be used for resume submission and competitive scholarships such as those offered by NJIT.

Prerequisite: Computer Aided Drafting II

Course #: 5240
Level: II
Grade: 11
Credits: 2.5

Course Title: **DRONE TECHNOLOGY AND CAREERS LEVEL 1**

Description: This course is intended for 11th grade students who wish to further their education in the field of drone technology and careers. This is an introductory course that centers around assemble, programing and basic flight instruction of multi-rotor drones. Design projects will provide real world applications and offer insight on the career pathways. Student selection to this course will be done on a lottery system basis and space will be limited. This course includes preparation, training and the potential to assessment for the Federal Aviation Administration Part 107 (14 CFR107.61) Remote Pilot Certification with a Small Unmanned Aircraft Systems Rating. This licensure will enable proficient students the ability to legally fly drones for commercial purposes.

Prerequisites: Completion of Geometry and Junior (11th grade) status.

Course #: 5245
Level: II
Grade: 11
Credits: 2.5

Course Title: **DRONE TECHNOLOGY AND CAREERS LEVEL 2**

Description: This course is intended for 11th grade students who wish to further their education in the field of drone technology and careers. In this course students will learn about First Person View (FPV) setup and equipment installation of cameras, transmitters and receivers (TX/RV) on multi-rotor drones; setup of ground stations, monitors, FPV goggles and advanced FPV flight instruction. Design projects will provide real world applications and offer insight on the career pathways.

Prerequisites: Completion of Geometry, completion of Drone Technology and Careers Level 1, and Junior (11th grade) status.

Course #: 5250
Level: III
Grade: 12
Credits: 5

Course Title: **DRONE TECHNOLOGY AND CAREERS LEVEL 3 AND 4 (H)**

Description: This course is intended for 12th grade students who wish to advance and further their education in the field of drone technology and careers. In this course students will learn about programming and setup of fully autonomous auto piloting (APM) on multi-rotor drones and perform full autonomous flight within Federal Aviation Administration (FAA) guidelines. Projects will provide real world applications and offer insight on the career pathways.

Prerequisites: Completion of Geometry, completion of Drone Technology and Careers Level 1 and 2, and Senior (12th grade) status.

WORLD/FOREIGN LANGUAGES SUGGESTED COURSE SEQUENCES

INTRODUCTION: One year of a World Language is required for high school Graduation. Most four-year colleges require two years of a sequential World Language course. However, four years of a sequential World Language is highly recommended and highly looked upon by colleges and universities. Students in surrounding South Jersey High Schools are competing with academics and perusing four years of a language. This highlights the students' tenacity. Our school offers four years of French, Italian, and Spanish. These courses are taught at academic level. A second or third year student entering an honors level course or a college prep level course will be required to complete a summer assignment. This assignment will be given to each in June. Students entering the course at a later date are required to obtain the assignment from the Guidance Department prior to entering the course. The summer assignment will be handed in on the first day of school.

Note: All students who wish to start a World Language in 9th grade and have completed a full year of Spanish 1 will be placed according to their final grade. Students who have been enrolled in honor courses and received a final grade of 92 or higher will be placed into a Spanish 2 Honors class. If you were enrolled in Honor courses and you received an 83 to a 91 final grade you will be placed in a Spanish 1 Honors class. All other students will be placed accordingly in a Spanish 1 College prep or an Intro to Spanish class.

Note: Seniors that completed and/or are currently enrolled in a level (3) or higher World language course(s) and that have demonstrated proficiency in English are eligible for a great opportunity to graduate with a State Seal of Biliteracy from the State of New Jersey. The State Seal of Biliteracy is a designation from the New Jersey Department of Education (NJDOE) identifying graduating high school students who are able to demonstrate proficiency in English in addition to one or more languages.

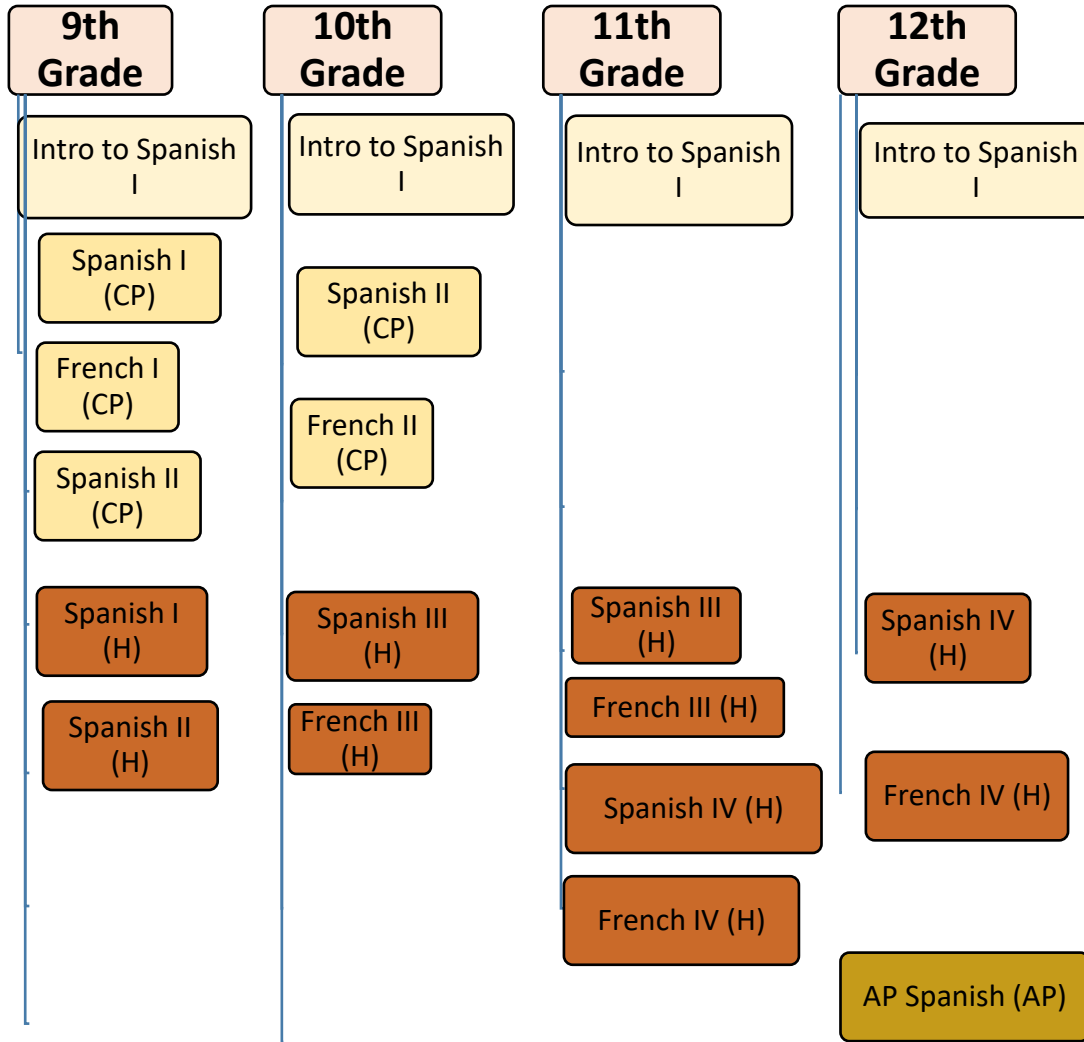

Note: Students who wish to start a World Language in Grade 9 must have earned a final grade of 83 or better in a previous language course and Language Arts/Reading course. Double-starred (**) courses are eligible for credit from Camden County College.

INTRODUCTION: One year of a world language is required for high school Graduation. However, two years of a sequential World Language are required by most four-year colleges. Our school offers four years of French, Italian, and Spanish. These courses are taught at academic level. A second- or third-year student entering an honors level course will be required to complete a summer assignment. This assignment will be given to each in June. Students entering the course late are required to obtain the assignment from the Guidance Department prior to entering the course. The summer assignment will be handed in on the first day of school. To enroll in a World Language course in grade 9, incoming students must have earned an 83 or better in a previous World Language course. New students to the district in all grades may take a written assessment to determine placement.

Course #: 4220
Level: I
Grade/s: 9-10-11-12
Credits: 5

Course Title: **INTRODUCTION TO FRENCH**

Description: This course will concentrate on fostering student basic communication skills in French through listening, speaking, reading and writing activities. Using practical application of culturally-authentic materials, students will learn basic phrases and commands in French. Students will learn about the customs, history, geography and cultures of French speaking countries.

Course #: 4230
Level: II
Grade/s: 9-10-11-12
Credits: 5

Course Title: **FRENCH I**

Description: This course provides for the learning of basic skills and elementary comprehension of the language. The student will gain the ability to read and pronounce French correctly and carry on simple conversations. There will also be an emphasis on understanding the French culture.

Course #: 4231
Level: II
Grade/s: 9-10-11-12
Credits: 5

Course Title: **FRENCH II**

Description: This course provides for greater comprehension of the language with an emphasis on the principles of grammar, composition and translation. The student will demonstrate further proficiency in speaking and reading skills. The study of history and culture of France will be covered through magazine and textbook readings as well as videos.

Prerequisite: French I

Course #: 4232
Level: III
Grade/s: 10-11-12
Credits: 5

Course Title: **FRENCH III – Honors**

**Eligible for college credits from Camden County College-listed as Elementary French I

Description: This course is aimed at the greater development of the student's ability to read, speak and listen in the language. The student is helped to find enjoyment in the beauty of the language and an appreciation in the literature. Grammatical skills learned in previous years are reviewed and drilled so that the student's written and oral expression in French is clear and correct. Improvement of conversation skills is stressed using current topics of interest. French culture, history and geography are studied in greater depth. Classes are conducted in French as much as possible.

Prerequisite: French II, Honors Prerequisite, and teacher recommendation

Course #: 4233
Level: III
Grade/s: 11-12
Credits: 5

Course Title: **FRENCH IV - Honors**

**Eligible for college credits from Camden County College-listed as Elementary French II

Description: The major objective of this course is for students to gain a greater understanding and fluency in the language. Students will use a wide variety of resources to learn about the cultures of the French-speaking world. Students will read four novelettes.

Prerequisite: French III Honors with 85 or better prerequisite, and teacher recommendation

Course #: 4234
Level: I
Grade/s: 9-10-11-12
Credits: 5

Course Title: **INTRO TO SPANISH**

Description: This course will concentrate on fostering student basic communication skills in Spanish through listening, speaking, reading and writing activities. Using practical application of culturally authentic materials, students will learn basic phrases and commands in Spanish. Students will learn about the customs, history, geography and cultures of Hispanic-American countries. They will also learn the many contributions Hispanics-Latinos have made to our society. This course is for Non-College bound students and is not considered an academic unit for college admission.

Course #: 4235
Level: II
Grade/s: 9-10-11-12
Credits: 5

Course Title: **SPANISH I**

Description: Spanish I will enable students to master basic structures of Spanish and apply them in everyday situations. Listening comprehension, speaking, reading and writing skills are acquired along with a greater understanding and appreciation of customs, traditions, history and geography of the Spanish speaking world. Spanish may be the key to the job you desire, a requirement to enter college, an increased understanding of the English language and self-enrichment.

Prerequisite: Student must be placed in at least on other College Prep Course, preferably English

Course #: 4236

Level: II

Grade/s: 9-10-11-12

Credits: 5

Course Title: **SPANISH II**

Description: This course extends the fundamentals of speaking, reading and writing which were developed in Spanish I. Vocabulary development and grammar will be stressed as well as the ability to understand and communicate in Spanish on a basic level. Selected readings will be used in translation activities. Multi-media materials will be employed to practice the four skills of speaking, listening, reading and writing. Further study of Hispanic culture, life and history will be used to develop appreciation of the language and the people.

Prerequisite: Successful completion of a full year of the Spanish 1 course in the middle school or successful completion of the Spanish 1 College Prep level course in the high school

Course #: 4254

Level: II

Grade/s: 10-11-12

Credits: 5

Course Title: **SPANISH III - College Prep**

Description: This course offers extensive oral practice in the language through class conversations, question and answer sessions, and group work. Grammatical concepts are reviewed, and more complex grammatical structures are introduced. Readings include excerpts from Hispanic literature featuring aspects of daily life in the Hispanic world writing skills are stressed through composition work. The class is conducted in Spanish.

Prerequisite: Successful completion of a full year of the Spanish 2 College Prep course

Course #: 4250

Level: III

Grade/s: 9-10-11-12

Credits: 5

Course Title: **SPANISH I - Honors**

Description: Spanish I is the first course in a multi-year sequence. Designed for students who are new to the study of Spanish but are ready to work at an accelerated pace in preparation for honor level studies in future years. The students will be introduced to Hispanic literature and will be expected to pursue a deeper understanding of language usage including the many aspects of Spanish and Hispanic life and culture. Activities will be developed of the students' ability to express ideas in Spanish and to think in the target language.

Prerequisite: Student must be placed in at least one other Honor Course, preferably English

Course #: 4252

Level: III

Grades/s: 9-10-11-12

Credits: 5

Course Title: **SPANISH II HONORS**

Prerequisite: Successful completion of a full year of the Spanish 1 course in the middle school or successful completion of the Spanish 1 Honors level course in the high school

Description: Spanish is part of a multi-year sequence. Designed for students who are continuing the study of Spanish but are ready to continue to work at an accelerated pace in preparation for honor level studies in future years. This course provides a deeper understanding and facility in using the language, an emphasis on the refinement of reading skills with extensive culturally authentic pieces, an intense development of writing skills and a profound study of the important aspects of Hispanic life and culture are emphasized. Activities will be developed of the students' ability to express ideas in Spanish and to think in the target language.

Course #: 4237

Level: III

Grade/s: 10-11-12

Credits: 5

Course Title: **SPANISH III – Honors**

**Eligible for college credits from Camden County College-listed as Elementary Spanish I

Description: This course is designed to improve skills in Spanish with emphases on student refinement of speaking and writing skills. Students study literature, grammar with exposure to present, past, future and subjunctive tenses. Emphasis is placed on conversation, composition, reading, and translating. Speeches, dialogs, supplemental materials, games and individual small group projects work to this end. This is a dual credit course with Camden County College. Students who meet college standards are eligible to receive college credit in addition to high school credit. An effort is made to conduct class in Spanish.

Prerequisite: Spanish II Honors prerequisite teacher recommendation consisting of emphasis on speaking ability.

Course #: 4238

Level: III

Grade/s: 11-12

Credits: 5

Course Title: **SPANISH IV-Honors**

**Eligible for college credits from Camden County College-listed as Elementary Spanish II

Description: This course is designed to help the student speak and read Spanish on a deeper level and develop an appreciation for Hispanic literature. This course emphasizes student refinement of speaking and writing skills, through discussion and conversations in Spanish. The course will be conducted predominantly in Spanish. This course provides a general background of Spanish life through the use of native speakers, foods, fashion, games, and multi-media activities. This is a dual credit course with Camden County College. Therefore, students who meet college standards are eligible to receive college credit in addition to high school credit. An effort is made to conduct class in Spanish.

Prerequisite: 83 or better in Spanish III Honors and teacher recommendation with an emphasis on speaking ability.

Course #: 4239
Level: IV
Grade/s: 11-12
Credits: 5

Course Title: **AP SPANISH**

**Eligible for college credits from Rowan College at Burlington County- listed as Elementary Spanish I & II; Intermediate Spanish I & II

Description: The AP Spanish Language and Culture course is a rigorous college level course. It is taught exclusively in Spanish that helps students improve proficiency in the interpretative, interpersonal, and presentational modes of communication in order to prepare students for the AP experience. This course builds upon the skills and content studied in the previous three or four years of the language. Successful students in the advanced language course should: “demonstrate an understanding of culture(s), incorporate interdisciplinary topics (connections), make comparisons between the native language and the target language and between cultures (comparisons), and use the target languages in real life settings (communities).

Prerequisite: 85 or better in Spanish III course. Recommendation required by previous Spanish teacher. Student must be highly motivated with sufficient time to prepare out-of-class reading and writing assignment.

COURSE SELECTION

In order to graduate from Winslow Township High School, a student must pass the State of New Jersey Graduation requirements and complete the following courses, to total 120 credits:

English 9, 10, 11, 12 (20 credits)
World History and U.S. History I, II (15 credits)
Principles of Economics (2.5 credits)
Three years of Mathematics (15 credits)
Three years of Science (15 credits)
One year in the Visual, Practical, or Performing Arts (5 credits)
One year of
(5 credits)
One year of P.E./Health for each year of enrollment (20 credits)*
One year of Career Ed or Consumer Family & Life Skills or
Vocational-Technical Education (5 credits)
Electives (20 credits)

Note: The completion of the high school graduation requirements is anticipated to occur within a four (4) year period.

Course Withdrawals:

Students may elect to withdraw from a course, provided that their schedule contains no more than one study hall resulting from the course withdrawal, according to the timeline listed below:

Year Courses – No later than Mid 1st Marking Period.

Semester Courses – No later than September 30th for fall semester courses and no later than February 28th for spring semester courses.

**COLLEGE BOUND STUDENTS
COURSE SELECTION**

In order for a student to be prepared to enroll in a 4-year college or university AND to be eligible to participate in college athletics (Div. 1 and 2) they must successfully complete a minimum of 16 academic units (college prep or higher level): Below reflects a recommended high school program for college prep students and serious athletes:

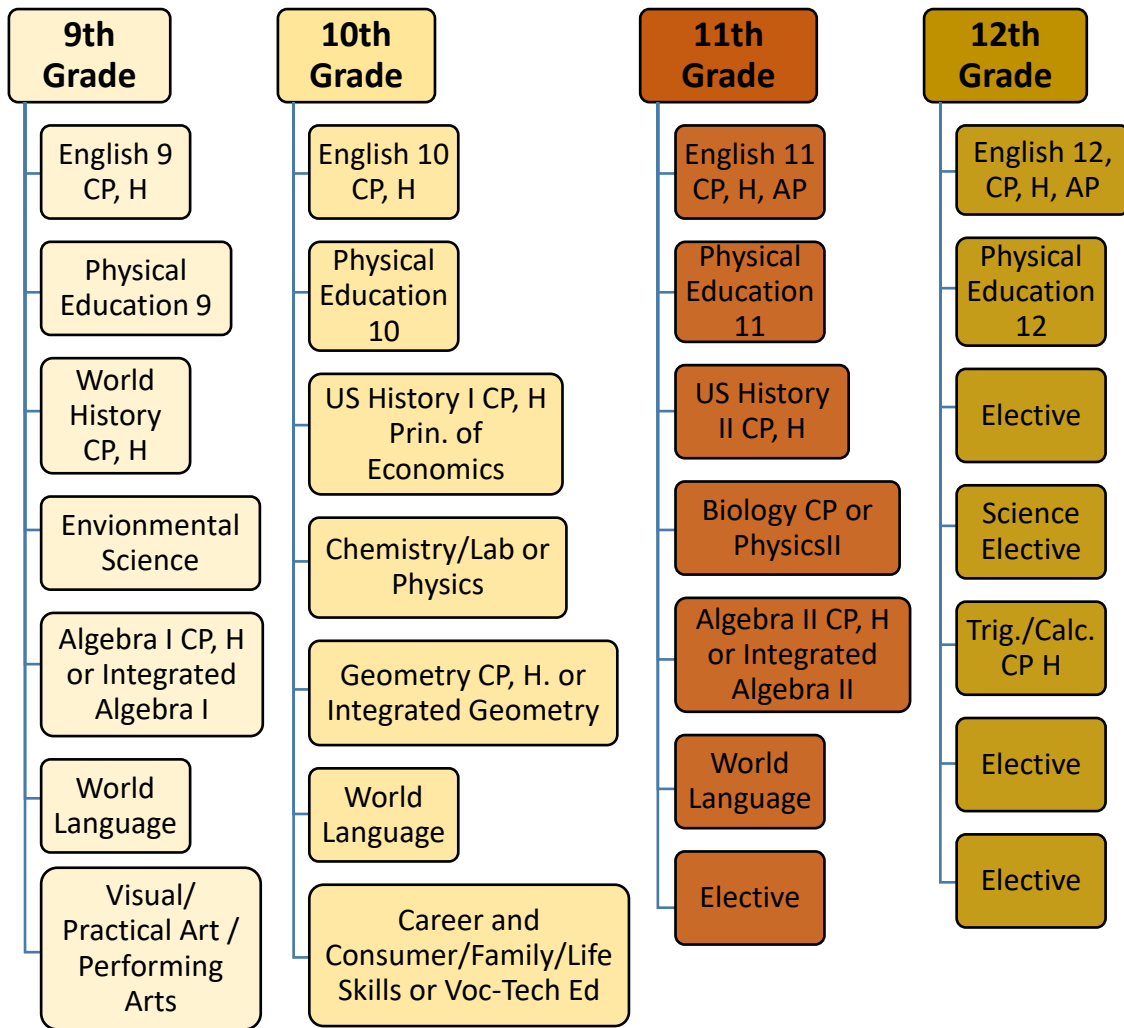

Winslow Township High School
Approved NCAA Courses
48-H

The following courses have been approved by NCAA and appear on our current 48-H form

- 2035 English 9 - Honors
- 2040 English 9 – College Preparatory
- 2055 English 9 - Modified
- 2481 Word Empowerment - Modified
- 2135 English 10 - Honors
- 2140 English 10– College Preparatory
- 2155 English 10 - Modified
- 2235 English 11 - Honors
- 2240 English 11– College Preparatory
- 2255 English 11 - Modified
- 2330 Literature & Composition – Advanced Placement
- 2335 English 12 – British Lit. - Honors
- 2340 English 12 – British Lit. – College Preparatory
- 2345 English 12 – British Lit
- 2355 English 12 - Modified
- 2440 Journalism
- 2445 Creative Writing
- 2425 Speech/Public Speaking
- 2434 Poetry Appreciation
- 2530 World History - Honors
- 2535 World History – College Preparatory
- 2827 World History – Advanced Placement
- 2545 World History - Modified
- 2630 US History I - Honors
- 2635 US History I – College Preparatory
- 2645 US History I - Modified
- 2730 US History II - Honors
- 2735 US History II – College Preparatory
- 2745 US History II - Modified
- 2800 Sociology
- 2805 Psychology
- 2806 Applied Psychology
- 2808 Forensic Psychology
- 2812 Psychology - Honors
- 2811 Psychology – Advanced Placement
- 2825 US History – Advanced Placement
- 2890 Government – Advanced Placement
- 2865 African American History
- 2866 African American History - Modified
- 2845 Criminal Law

2846 Civil Law
2850 Genocide in 20th Century
2835 Principles of Economics
3075 Lab Biology - Honors
3130 Lab Biology – College Preparatory
3220 Anatomy & Physiology – College Preparatory
3221 Anatomy & Physiology - Honors
3225 Biology – Advanced Placement
3190 Physical Science Lab
3175 Chemistry/Lab - Honors
3180 Chemistry/Lab – College Preparatory
3202 Chemistry – Advanced Placement
3231 Environmental – Advanced Placement
3260 Concepts of Science - Modified
3215 Physics/Lab - Honors
3206 Physics – Advanced Placement
3217 Physics/Lab– College Preparatory
3247 Zoology
3251 Marine Biology
3252 Forensic Science - Honors
3550 Integrated Algebra I
3555 Integrated Geometry
3585 Algebra I – College Preparatory
3587 Algebra I - Honors
3590 Algebra II - Honors
3595 Algebra II – College Preparatory
3596 Integrated Algebra II
3690 Geometry - Honors
3695 Geometry – College Preparatory
3750 Trigonometry - Honors
3755 Trigonometry/Pre-Calculus
3765 Calculus - Honors
3770 Calculus-AB – Advanced Placement
3771 Calculus-BC
3772 Statistics – Advanced Placement
4230 French I
4231 French II
4232 French III - Honors
4233 French IV- Honors
4235 Spanish I
4236 Spanish II
4237 Spanish III - Honors
4238 Spanish IV - Honors
4239 Spanish – Advanced Placement

SUBJECT TO CHANGE BASED ON NCAA APPROVAL

Student Athlete NCAA Evaluation Worksheet

Comments:

As of August 1st 2016, 10 core courses must be completed before the seventh semester and 7 of the 10 must be a combination of English, Math, or Natural or Physical Science for competition purposes. Grades and credits may be earned at any time for academic red shirt purposes.

- Students need a 2.3 GPA to be NCAA eligible.
A higher GPA allows for a lower SAT score.
- Points are calculated based on the final letter grade earned: A = 5, B = 4, C = 3, D = 2
- Units are based on the length of a course: a full year course = 1 unit, a semester course = .5 unit
- 16 courses are required for eligibility

CORE COURSES

CORE COURSES			GRADES	POINTS	UNITS
ENGLISH (4)	1	English 9 CP / H			
	2	English 10 CP / H			
	3	English 11 CP / H / AP			
	4	English 12 CP / H / AP			
MATH (3)	1	Algebra 1 / Integrated Algebra			
	2	Geometry / Integrated Geometry			
	3	Algebra II / Integrated Algebra II			
NAT./PHYS. SCIENCE (2)	1	Biology CP / H			
	2	Chemistry CP / H			
SOCIAL SCIENCE (3)	1	World History CP / H			
	2	US History 1 CP / H			
	3	US History 2 CP / H			
ACADEMIC ELECTIVES (2-4)	1	World Language CP / H			
	2	World Language CP / H			
	3	Trigonometry / Pre- calculus			
	4	Environmental Science CP / Physics H			

FOUR-YEAR SCHEDULE PLANNER

FRESHMAN YEAR 9th Grade	CREDITS
COURSE/LEVEL	
English 9 CP	
Mathematics (Algebra)	
Science (Environmental)	
World History CP	
World Language	
Elective/Freshman Seminar	
Physical Education 9	
Lunch	XX
TOTAL	

Alternative Electives:

SOPHOMORE YEAR 10th Grade (27.5 Credits)	CREDITS
COURSE/LEVEL	
English 10 CP	
Mathematics (Geometry)	
Science (Chemistry)	
U.S. History CP	
Principles of Economics	
World Language II	
Elective	
Physical Education 10	
Lunch	XX
TOTAL	

Alternative Electives:

JUNIOR YEAR 11th Grade (55 Credits)	CREDITS
COURSE/LEVEL	
English II CP	
Mathematics (Algebra II)	
Science (Biology)	
U.S. History II CP	
Visual and/or Performing Arts	
Physical Education 11	
Lunch	XX
TOTAL	

Alternative Electives:

SENIOR YEAR 12th Grade (82.5 Credits)	CREDITS
COURSE/LEVEL	
English 12 CP	
Science Elective	
Math Elective	
Physical Education 12	
History Elective	XX
TOTAL	

Alternative Electives:
